

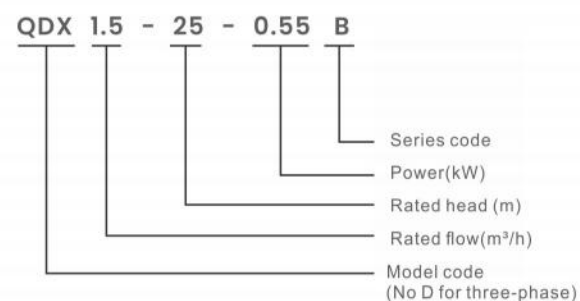

QDX-B Submersible Pump



Model Definition



Feature

- New industrial design, lower motor temperature rise.
- Optimized motor design, improved efficiency.
- Alloy impeller of high performance engineering plastics or aluminum.

Application

QDX series pumps are widely applied in industry, agriculture, mining, construction, municipal, environmental protection, etc. They are suitable for draining water containing particles such as short fibers, paper scraps, etc. and soft solid, such as muddy water, dirty water, domestic wastewater, sewage, manure, etc. They are ideal equipment for agricultural irrigation and drainage, poolsilt cleaning and site construction, but do not apply to the location with explosion-proof requirements.

Operating Condition

- Maximum liquid temperature +40°C
- pH level from 6.5-8.5
- Maximum sand content is 0.1%. Passage of suspended solids up to 0.2mm
- Power frequency is 50Hz.
- Nominal voltage is 220VAC for single phase and 380VAC for three phase with the range from -10% to 10%.
- Immersion depth from 0.5m-5m

Options On Request

Other voltage or frequency is 60Hz

Performance Range

Max.flow: 68m³/h
Max.head: 33m

Performance Curve

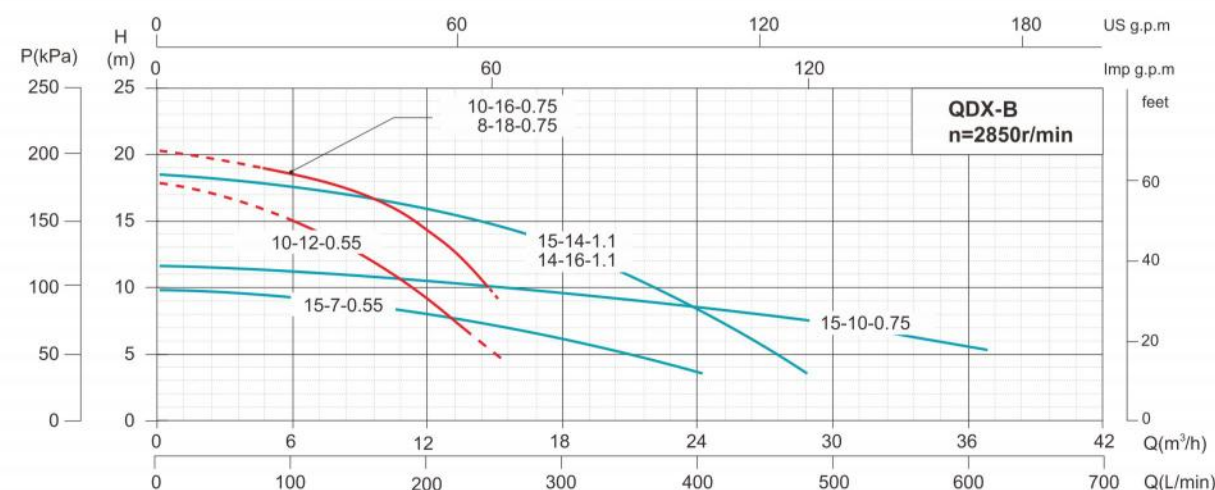
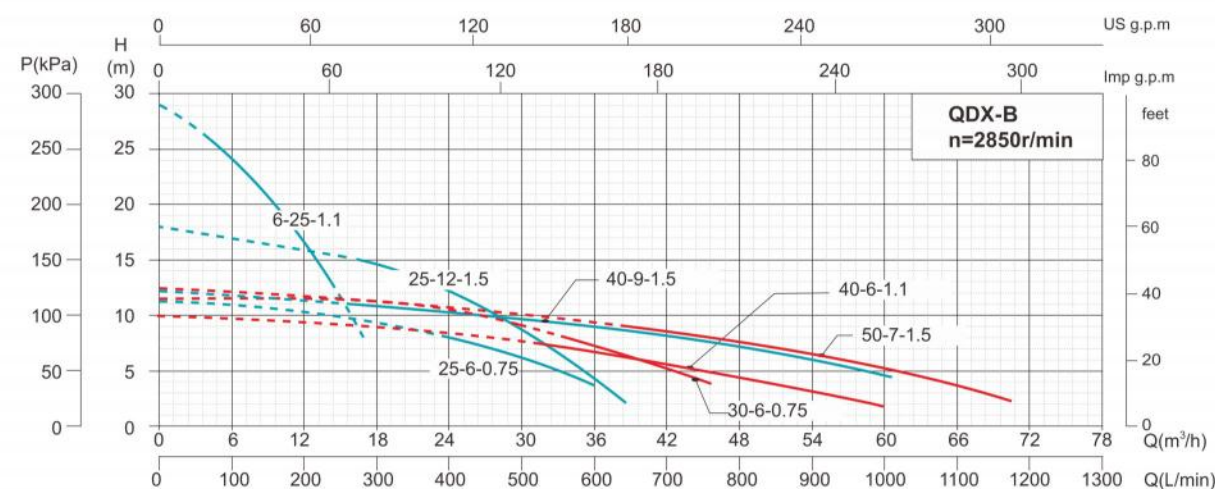
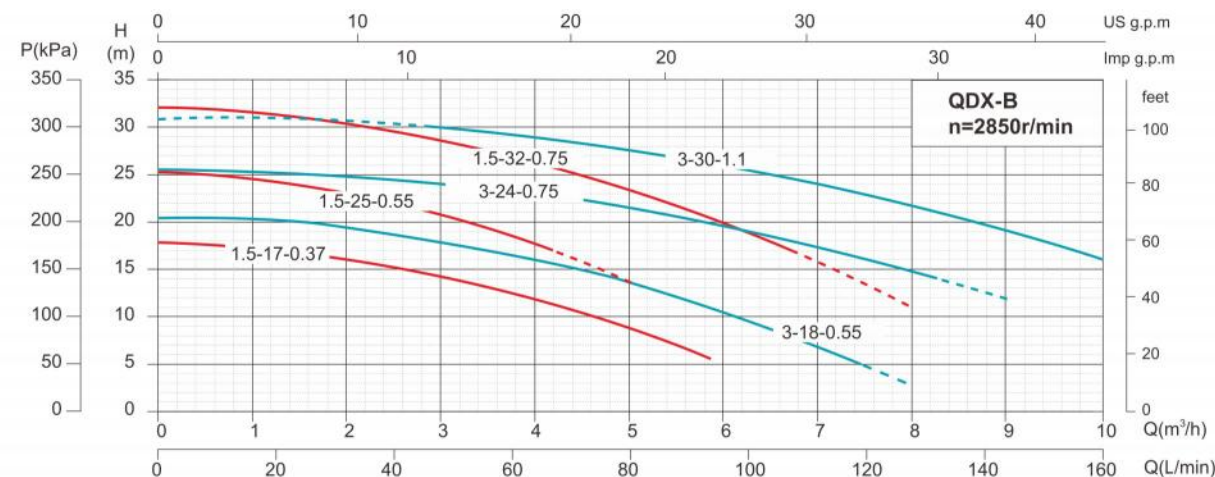

Components & Materials

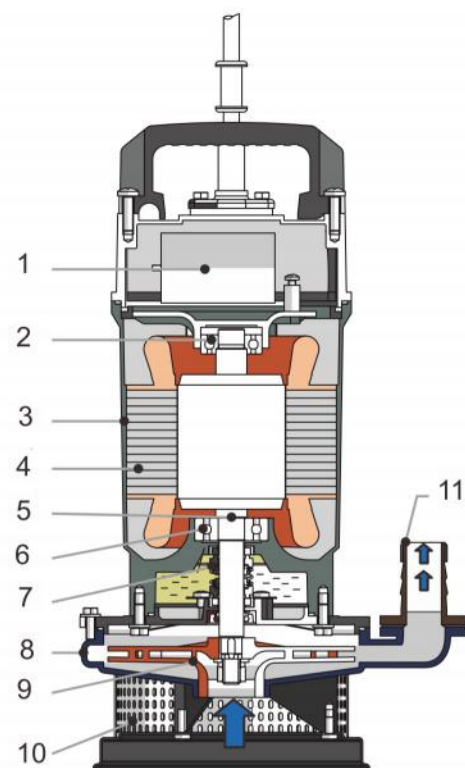

	Power(kW)	0.37	0.55	0.75	1.1	1.5
1	Capacitor (uF)	12uF/450V AC	18uF/450V AC	25uF/450V AC	30uF/450V AC	35uF/450V AC
2	Upper bearing	6201-2RZ	6202-2RZ	6202-2RZ	6202-2RZ	6202-2RZ
3	Motor Case	YL102				
4	Motor	Dry submersible motor				
5	Motor shaft	Steel 45#				
6	Lower bearing	6202-2RZ	6302-2RZ	6302-2RZ	6204-2RZ	6204-2RZ
7	Mechanical seal	208-14/35 B:A/B:A(PTC)	208-14/35 B:A/B:A(PTC) 208-14/35(2) B:A/B:S(PTC)	208-14/35 B:A/B:A(PTC) 208-14/35(2) B:A/B:S(PTC)	208-18/38 B:A/B:A(PTC) 208-18/38(2) B:A/B:S(PTC)	208-18/38 B:A/B:A(PTC)
		A:Hot-pressing graphite B:Alumina ceramic				
8	Pump body	50-7/40-9/40-6/30-6/15-14 is HT200,The other is ZL102.				
9	Impeller	ZL102、 PPOG30				
10	Fitter screen	Q235A / 430				
11	Outlet	HT200				

Dimension & Weight

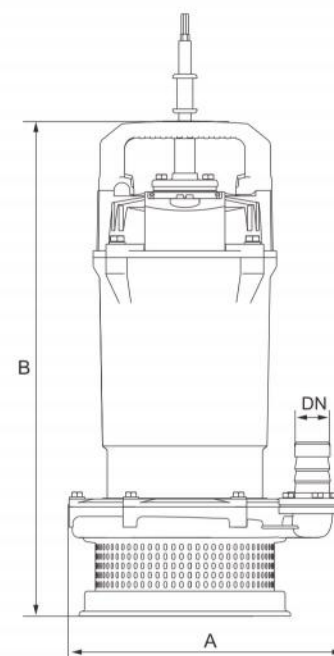

Model		Dim.(mm)			N.W. (kg)
Single-phase	Three-phase	A	B	DN	
QDX1.5-17-0.37B	-	195	360	1"	6.5
QDX1.5-25-0.55B	-	220	370	1"	9.5
QDX3-18-0.55B	-	210	370	1.25"	9.5
QDX10-12-0.55B	-	215	375	1.5"	9.5
QDX15-7-0.55B	-	210	385	2"	9.5
QDX1.5-32-0.75B	-	245	390	1"	11.5
QDX3-24-0.75B	-	220	390	1.25"	11
QDX8-18-0.75B	-	230	395	1.5"	11
QDX10-16-0.75B	-	230	395	2"	11.5
QDX15-10-0.75B	-	245	405	2.5"	12
QDX25-6-0.75B	-	245	395	3"	11.5
QDX30-6-0.75B	-	265	420	3"	16
QDX6-25-1.1B	-	240	430	2"	14
QDX3-30-1.1B	-	235	425	1"	13
QDX14-16-1.1B	-	250	435	2"	16
QDX15-14-1.1B	-	250	435	2.5"	16
QDX40-6-1.1B	-	270	465	3"	17.5
QDX50-7-1.5B	-	300	500	4"	23
-	QX3-30-1.1B	235	425	1"	11.5
-	QX6-25-1.1B	240	430	2"	13
-	QX40-6-1.1B	270	465	3"	16
-	QX15-14-1.1B	250	435	2.5"	15
-	QX40-9-1.5B	270	490	3"	18
-	QX25-12-1.5B	250	465	2.5"	17
-	QX50-7-1.5B	300	500	4"	22

Performance Detail & Dimension & Weight

Model		Power		Rate Current (A)	Max.Flow (m ³ /h)	Max.Head (m)	Head Range (m)	Cable line (mm ² -m)	Dim.mm (L×W×H)	G.W. (kg)	20' Loading Qty. (pcs)	
Single-phase	Three-phase	kW	HP									
QDX1.5-17-0.37B	-	0.37	0.5	2.9	6	18	4~18	3*0.75-8	385×160×220	7	2100	
QDX1.5-25-0.55B	-	0.55	0.75		4.1	6.5	26	17~26	3*0.75-8	395×195×220	10	1680
QDX3-18-0.55B	-	0.55	0.75			8	20	5~20	3*0.75-8	410×180×220	10	1680
QDX10-12-0.55B	-	0.55	0.75			15	18	7~15	3*0.75-8	410×210×220	10	1500
QDX15-7-0.55B	-	0.55	0.75			24	9	2~9	3*0.75-8	410×210×220	10	1500
QDX1.5-32-0.75B	-	0.75	1	5.2	8	33	17~32	3*0.75-8	420×210×230	12	1500	
QDX3-24-0.75B	-	0.75	1		9	25	14~25	3*0.75-8	410×190×220	115	1680	
QDX8-18-0.75B	-	0.75	1		15	20	15~19	3*0.75-8	420×195×230	115	1620	
QDX10-16-0.75B	-	0.75	1		15	20	10~19	3*0.75-8	420×195×230	12	1620	
QDX15-10-0.75B	-	0.75	1		36	12	3~11	3*0.75-8	420×220×240	12.5	1345	
QDX25-6-0.75B	-	0.75	1		35	11	0~8	3*0.75-8	420×220×260	12	990	
QDX30-6-0.75B	-	0.75	1		45	11	0~8	3*0.75-8	450×280×225	17	1242	
QDX6-25-1.1B	-	1.1	1.5		7.3	17	29	13~26	3*1.5-8	465×285×205	15	1010
QDX3-30-1.1B	-	1.1	1.5			10	31	0~30	3*1.5-8	455×285×225	14	990
QDX14-16-1.1B	-	1.1	1.5			29	18	14~18	3*1.5-8	465×285×225	17	940
QDX15-14-1.1B	-	1.1	1.5	29		18	0~17	3*1.5-8	465×285×225	17	940	
QDX40-6-1.1B	-	1.1	1.5	60		10	0~7.5	3*1.5-8	490×285×225	18.5	1050	
QDX50-7-1.5B	-	1.5	2	9.5	68	12	0~9	3*1.5-8	550×325×230	25	1010	
-	QX3-30-1.1B	1.1	1.5	2.7	10	31	0~30	4*0.75-8	455×285×225	12.5	990	
-	QX6-25-1.1B	1.1	1.5		17	29	13~26	4*0.75-8	465×285×225	14	940	
-	QX40-6-1.1B	1.1	1.5		60	10	0~7.5	4*0.75-8	490×285×225	17	990	
-	QX15-14-1.1B	1.1	1.5		29	18	0~17	4*0.75-8	465×285×225	16	880	
-	QX40-9-1.5B	1.5	2	3.6	61	12	0~11	4*0.75-8	525×285×225	19	735	
-	QX25-12-1.5B	1.5	2		37	18	0~15	4*0.75-8	495×285×225	18	936	
-	QX50-7-1.5B	1.5	2		3.6	68	12	0~9	4*0.75-8	550×325×230	24	1010

Centrifugal pumps are not recommended to be used less than the lift range.

Note:QX3-30-1.1B is honeycomb box,QX50-7-1.5B is honeycomb box