



# PH Water Recirculation Pump



## Feature

- Impeller and rotating shaft are made of stainless steel, which is not rusted
- Flange connection, convenient disassembly and assembly
- Casting electrophoresis treatment, not easy to rust
- Stable operation, low vibration noise
- Thermal protector
- Insulation class:F
- Protection level:IP55

## Application

- Boiler feed water
- District regional water supply system
- District or district central heating system
- Central air conditioning system for refrigeration
- Washing system
- Domestic hot water system
- General industrial water system

## Operating Condition

Medium temperature:-20°C~104°C  
 Environmental temperature:≤65°C

## Model Definition

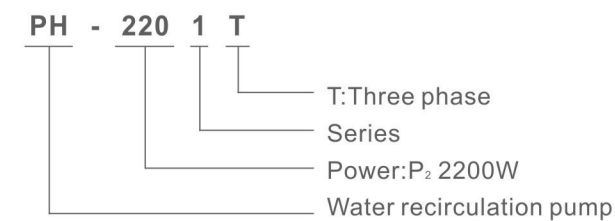

## Working Principle Diagram

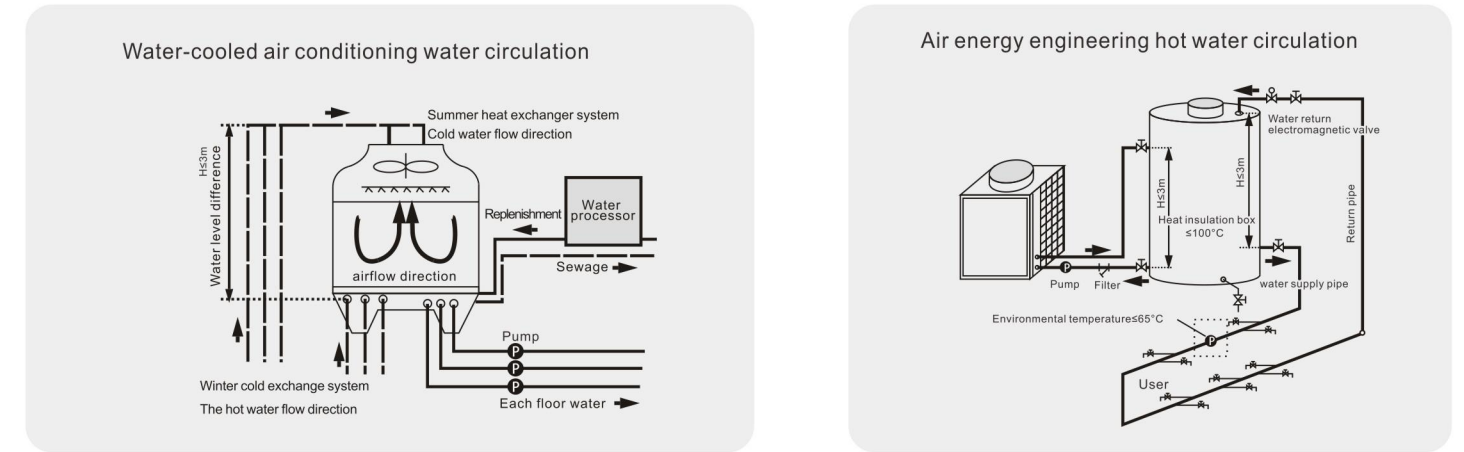

## Performance Table

Model	P2	Amps		Rated head m	Rated flow m³/h	G.W kg	Packing way	Packing dimension mm
	kW	220V/50Hz	380V/50Hz					
PH-043	40	0.4	-	2.5	2.1	5.5	Carton	270X250X215
PH-102	100	0.62	-	3	5.1	8		290X295X215
PH-150	150	1.5	-	3	11.1	11.5		335X355X260
PH-255	250	2.0	-	10	3	8.8		300X345X215
PH-255T	250	-	0.7	10	3	8.4		300X345X215
PH-257	250	2.0	-	4	13.5	15.5		350X380X280
PH-257T	250	-	0.7	4	13.5	14.9		350X380X280
PH-750	750	5.2	-	10	10.8	20		390X380X260
PH-750T	750	-	1.7	10	10.8	19.3		390X380X260
PH-751	750	5.2	-	16	7.8	20		390X380X260
PH-751T	750	-	1.7	16	7.8	19.3		390X380X260
PH-1501	1500	9.2	-	15	16	40		Wooden box
PH-1501T	1500	-	3.2	15	16	39	470X430X380	
PH-2201	2200	14	-	20	18.5	46	470X430X380	
PH-2201T	2200	-	4.6	20	18.5	44.5	470X430X380	

**Overall Dimension**

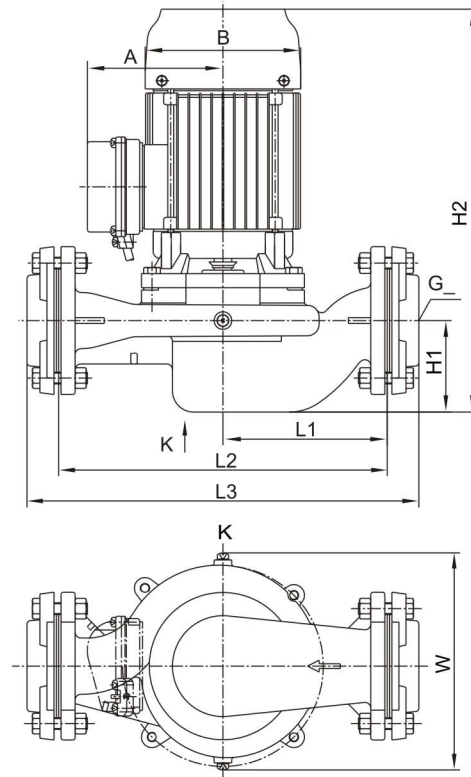

**Performance Curves**

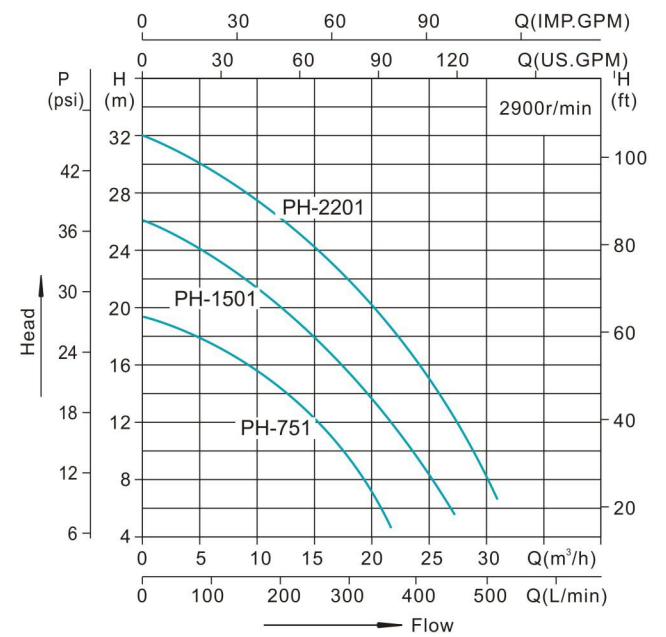
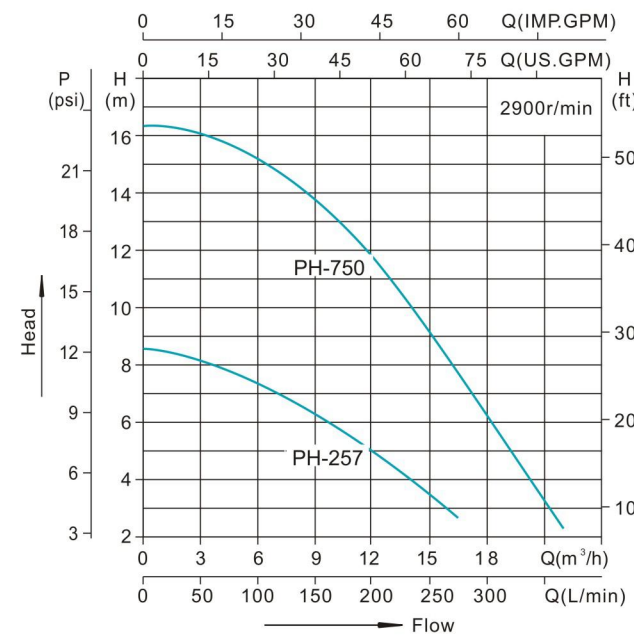
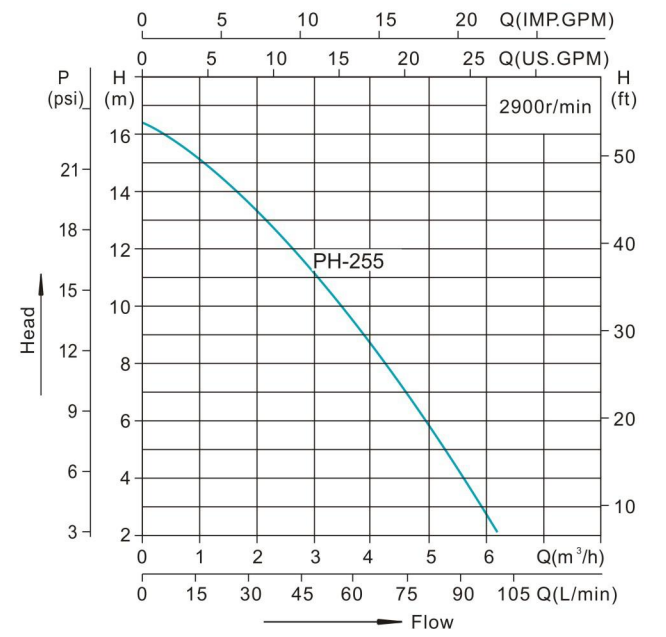
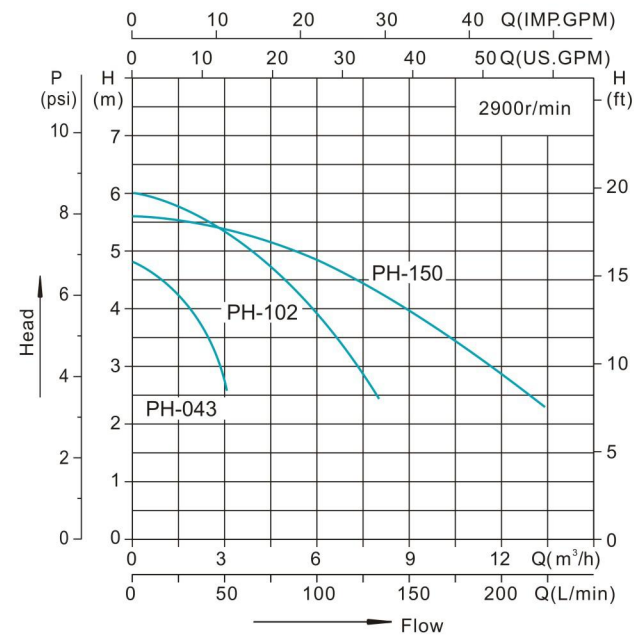

No.	Model	Dimension(mm)								Inlet and outlet aperture	
		L1	L2	L3	H1	H2	W	A	B	G__	DN
1	PH-043	75	150	194	29	228	115	109	120	G1	25
2	PH-102	105	210	260	46	243	141	109	120	G1.5	40
3	PH-150	130	260	312	69	292	183	107	120	G2	50
4	PH-255	130	260	310	44	256	153	107	120	G1.5	40
5	PH-255T							105			
6	PH-257	140	280	334	73	305	189	107	120	G2	50
7	PH-257T							105			
8	PH-750	140	280	334	78	344	185	116	133	G3	80
9	PH-750T							114			
10	PH-751	140	280	334	78	344	185	116	133	G2	50
11	PH-751T							114			
12	PH-1501	155	310	374	78	396	237	131	148	G2	50
13	PH-1501T							119			
14	PH-2201	155	310	374	78	424	237	140	165	G2	50
15	PH-2201T							128			