



# WQ Submersible Electric Sewage Pump



High temperature models can be customized

## Application

1. Sewage treatment systems for construction projects, industrial and mining enterprises, municipal engineering, etc
2. Pollutant discharge and sewage treatment in urban environmental protection systems
3. Exploration and mining supporting machinery
4. Agricultural irrigation, fish farming, water spraying, etc

## Product Overview

1. The impeller of the WQ(D) submersible sewage pump adopts a closed double channel design, which increases the service life of the product due to symmetrical flow channels, good balance, smooth operation, and low vibration. The flow passage has strong passing capacity, and the measured efficiency is higher than the national standard, which saves energy and reduces consumption.
2. The designed submersible motor has IP68 protection level and F insulation class, with good diving cooling effect, low temperature rise, and long insulation life. Over-current protectors are installed below 7.5kW to ensure that the motor can automatically cut off power in case of abnormal situations.
3. It adopts a double end mechanical seal, with an external skeleton oil seal below 7.5kW, and a two to three series mechanical seals for motor shaft seals above 11kW, forming multiple reliable sealing lines. One is in the medium inside the pump, effectively preventing water from entering the oil chamber, and the other is in the oil chamber to prevent oil from entering the motor chamber. The oil chamber is filled with suitable mechanical oil, while lubricating and cooling the friction surfaces of the two independent machine seals, making the machine seal work more reliable. In addition, it can also take away the heat generated by the lower bearings and some heat generated by the motor.
4. Some water pumps have special cable manufacturing processes that can completely prevent water from entering the motor through the small gaps between the wires when the cable skin is damaged or the front end of the cable is submerged in water.

## Operating Condition

1. Power supply: 50Hz, three-phase, 380V
2. Medium temperature:  $\leq 40^{\circ}\text{C}$ , volume ratio of solid matter transported by the medium:  $< 2\%$ , medium density:  $< 1200\text{kg/m}^3$
3. During operation, the minimum liquid level should not be lower than 2/3 of the motor's
4. Unable to adapt to media with corrosive fluids and particles
5. The diameter of the solid object in the medium shall not exceed the maximum allowable solid diameter

## Model Definition

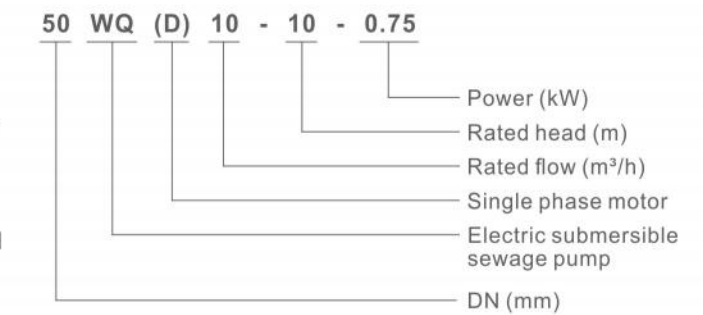

## Performance Curve

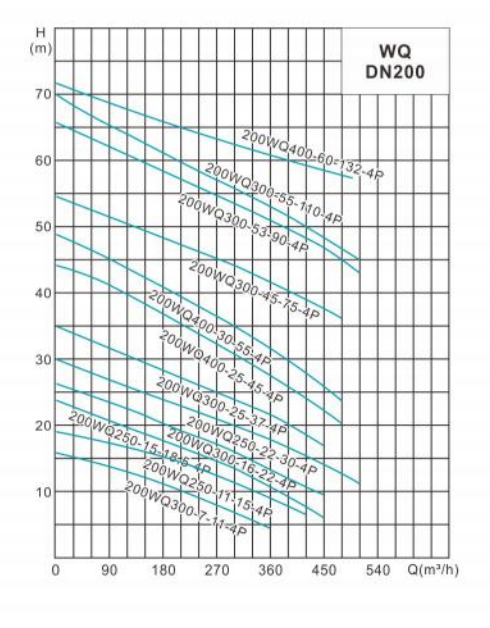
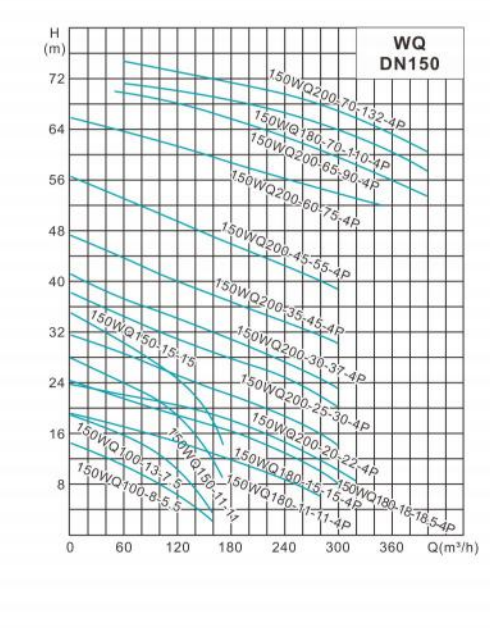
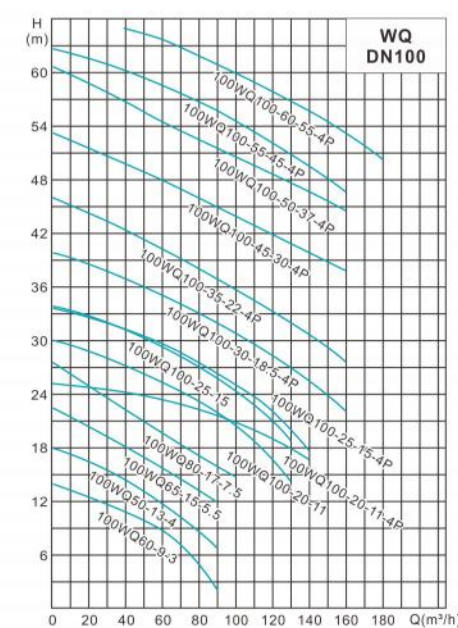
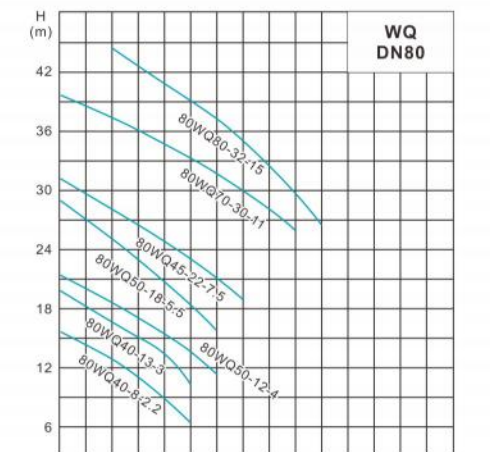
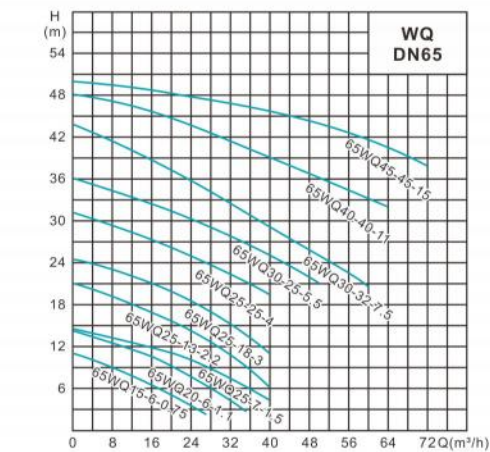
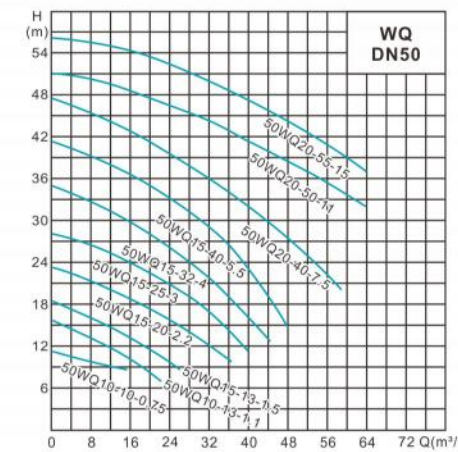

### Performance Curve

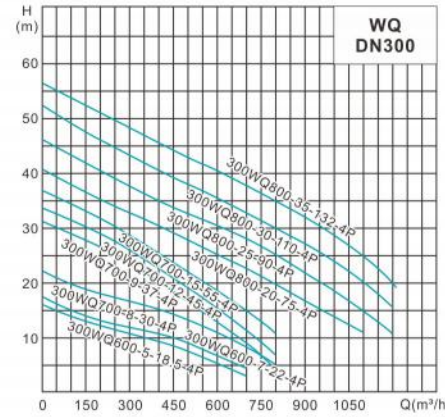
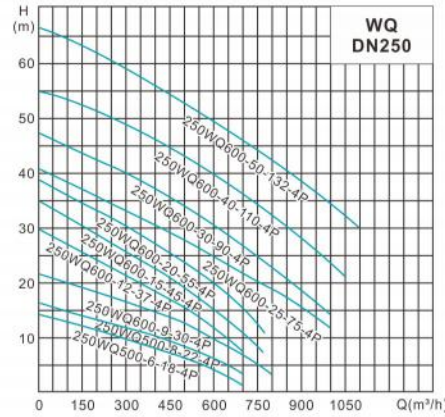

### Performance Table

Model	Rate flow (m <sup>3</sup> /h)	Rate head (m)	Rate power (kW)	Rated voltage (V)	Outlet (mm)	Speed (r/min)
50WQD10-10-0.75	10	10	0.75	220	50	2850
65WQD15-6-0.75	15	6	0.75	220	65	2850
50WQD10-13-1.1	10	13	1.1	220	50	2850
65WQD20-6-1.1	20	6	1.1	220	65	2850
50WQ10-10-0.75	10	10	0.75	380	50	2850
65WQ15-6-0.75	15	6	0.75	380	65	2850
50WQ10-13-1.1	10	13	1.1	380	50	2850
65WQ20-6-1.1	20	6	1.1	380	65	2850
50WQD15-15-1.5	15	15	1.5	220	50	2850
65WQD25-7-1.5	25	7	1.5	220	65	2850
50WQ15-15-1.5	15	15	1.5	380	50	2850
65WQ25-7-1.5	25	7	1.5	380	65	2850
50WQD15-20-2.2	15	20	2.2	220	50	2850
65WQD25-15-2.2	25	15	2.2	220	65	2850
50WQD40-9-2.2	40	9	2.2	220	50	2850
65WQ15-20-2.2	15	20	2.2	380	65	2850
65WQ25-15-2.2	25	15	2.2	380	65	2850
80WQ40-9-2.2	40	9	2.2	380	80	2850
50WQ15-25-3	15	25	3	380	50	2850
65WQ25-20-3	25	20	3	380	65	2850
80WQ40-15-3	40	15	3	380	80	2850
100WQ50-10-3	50	10	3	380	100	2850
50WQ15-32-4	15	32	4	380	50	2900
65WQ25-25-4	25	25	4	380	65	2900
80WQ40-18-4	40	18	4	380	80	2900
100WQ50-13-4	50	13	4	380	100	2900
50WQ15-40-5.5	15	40	5.5	380	50	2900
65WQ30-25-5.5	30	25	5.5	380	65	2900
80WQ50-18-5.5	50	18	5.5	380	80	2900
100WQ70-15-5.5	70	15	5.5	380	100	2900
150WQ100-8-5.5	100	8	5.5	380	150	2900
50WQ20-40-7.5(I)	20	40	7.5	380	50	2900

### Performance Table

Model	Rate flow (m <sup>3</sup> /h)	Rate head (m)	Rate power (kW)	Rated voltage (V)	Outlet (mm)	Speed (r/min)
65WQ30-32-7.5(I)	30	32	7.5	380	65	2900
80WQ45-22-7.5(I)	45	22	7.5	380	80	2900
100WQ80-18-7.5(I)	80	18	7.5	380	100	2900
150WQ100-13-7.5(I)	100	13	7.5	380	150	2900
50WQ20-40-7.5	20	40	7.5	380	50	2900
65WQ30-32-7.5	30	32	7.5	380	65	2900
80WQ45-22-7.5	45	22	7.5	380	80	2900
100WQ80-18-7.5	80	18	7.5	380	100	2900
150WQ100-13-7.5	100	13	7.5	380	150	2900
50WQ20-50-11	20	50	11	380	50	2900
65WQ40-40-11	40	40	11	380	65	2900
80WQ60-30-11	60	30	11	380	80	2900
100WQ100-20-11	100	20	11	380	100	2900
150WQ150-11-11	150	11	11	380	150	2900
200WQ200-8-11	200	8	11	380	200	2900
50WQ20-55-15	20	55	15	380	50	2900
65WQ45-45-15	45	45	15	380	65	2900
80WQ80-32-15	80	32	15	380	80	2900
100WQ100-25-15	100	25	15	380	100	2900
150WQ150-15-15	150	15	15	380	150	2900
200WQ220-10-15	220	10	15	380	200	2900
100WQ100-20-11	100	20	11	380	100	1450
150WQ180-11-11	180	11	11	380	150	1450
200WQ300-7-11	300	7	11	380	200	1450
100WQ100-25-15	100	25	15	380	100	1450
150WQ180-15-15	180	15	15	380	150	1450
200WQ250-11-15	250	11	15	380	200	1450
100WQ100-30-18.5	100	30	18.5	380	100	1450
150WQ180-18-18.5	180	18	18.5	380	150	1450
200WQ250-15-18.5	250	15	18.5	380	200	1450
250WQ500-6-18.5	500	6	18.5	380	250	1450
100WQ100-35-22	100	35	22	380	100	1450
150WQ200-20-22	200	20	22	380	150	1450
200WQ300-16-22	300	16	22	380	200	1450
250WQ500-8-22	500	8	22	380	250	1450
100WQ100-45-30	100	45	30	380	100	1450
150WQ180-30-30	180	30	30	380	150	1450
200WQ250-22-30	250	22	30	380	200	1450
250WQ600-9-30	600	9	30	380	250	1450
300WQ800-7-30	800	7	30	380	300	1450
100WQ100-50-37	100	50	37	380	100	1450
150WQ200-30-37	200	30	37	380	150	1450
200WQ350-25-37	350	25	37	380	200	1450
250WQ600-12-37	600	12	37	380	250	1450
300WQ800-9-37	800	9	37	380	300	1450
350WQ1000-6-37	1000	6	37	380	350	1450
100WQ100-55-45	100	55	45	380	100	1450
150WQ200-35-45	200	35	45	380	150	1450

## Performance Table

Model	Rate flow (m <sup>3</sup> /h)	Rate head (m)	Rate power (kW)	Rated voltage (V)	Outlet (mm)	Speed (r/min)
200WQ400-25-45	400	25	45	380	200	1450
250WQ600-15-45	600	15	45	380	250	1450
300WQ800-12-45	800	12	45	380	300	1450
350WQ1000-8-45	1000	8	45	380	350	1450
100WQ100-65-55	100	65	55	380	100	1450
150WQ180-50-55	180	50	55	380	150	1450
200WQ300-40-55	300	40	55	380	200	1450
200WQ400-30-55	400	30	55	380	200	1450
250WQ600-20-55	600	20	55	380	250	1450
300WQ800-15-55	800	15	55	380	300	1450
350WQ1000-10-55	1000	10	55	380	350	1450
150WQ200-60-75	200	60	75	380	150	1450
200WQ300-45-75	300	45	75	380	200	1450
250WQ600-25-75	600	25	75	380	250	1450
300WQ800-20-75	800	20	75	380	300	1450
350WQ900-15-75	900	15	75	380	350	1450
150WQ200-65-90	200	65	90	380	150	1450
200WQ300-55-90	300	55	90	380	200	1450
200WQ400-50-90	400	50	90	380	200	1450
250WQ600-30-90	600	30	90	380	250	1450
300WQ800-25-90	800	25	90	380	300	1450
350WQ1000-18-90	1000	18	90	380	350	1450
150WQ200-75-110	200	75	110	380	150	1450
200WQ400-55-110	400	55	110	380	200	1450
250WQ600-40-110	600	40	110	380	250	1450
300WQ800-30-110	800	30	110	380	300	1450
350WQ1000-22-110	1000	22	110	380	350	1450
150WQ200-80-132	200	80	132	380	150	1450
200WQ400-60-132	400	60	132	380	200	1450
250WQ600-50-132	600	50	132	380	250	1450
300WQ800-35-132	800	35	132	380	300	1450
350WQ1000-28-132	1000	28	132	380	350	1450