

LLT Vertical Cooling Tower Pipeline Pump

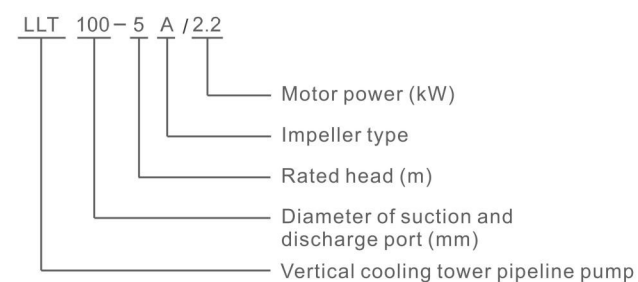

Model Definition



Structural Characteristic

The pump is non self-priming, single stage single suction vertical, with horizontal inlet and outlet water. The LLT pump shaft and motor shaft are connected coaxially, with a small footprint and light weight. Impeller, pump shaft and other key components are made of stainless steel. The casting adopts resin sand casting technology, with a smooth surface, good appearance quality, and dense organization. The impeller and pump body are designed using excellent hydraulic models, and the optimal operating conditions are customized according to market demand, resulting in high efficiency.

Application

The pump is mainly used for water circulation of closed cooling tower and condenser. It is also suitable for the cooling of various unit equipment; Can also be used for some large flow, low head occasions. The product is suitable for use in clean, thin, non corrosive, non flammable and explosive liquids, and does not contain any fixed particles and fibers that may cause mechanical or chemical damage to the pump. When used in situations where the liquid is viscous or dense, it can cause a decrease in the pump characteristic curve and an increase in energy consumption. Liquid temperature: -15°C~100°C Ambient temperature: Maximum 40°C Maximum working pressure: 6 bar

Curve Condition

The following principles apply to the performance curves:
 All curves are based on measured values of 3x380V at constant speed of 2900rpm and 1450rpm for the motor.
 The test medium is clean water at a temperature of 20°C without any solid impurities and air.
 The use of the pump refers to the performance range of the bold curve to prevent overheating and overload of the motor caused by too small flow rate.

Performance Curve

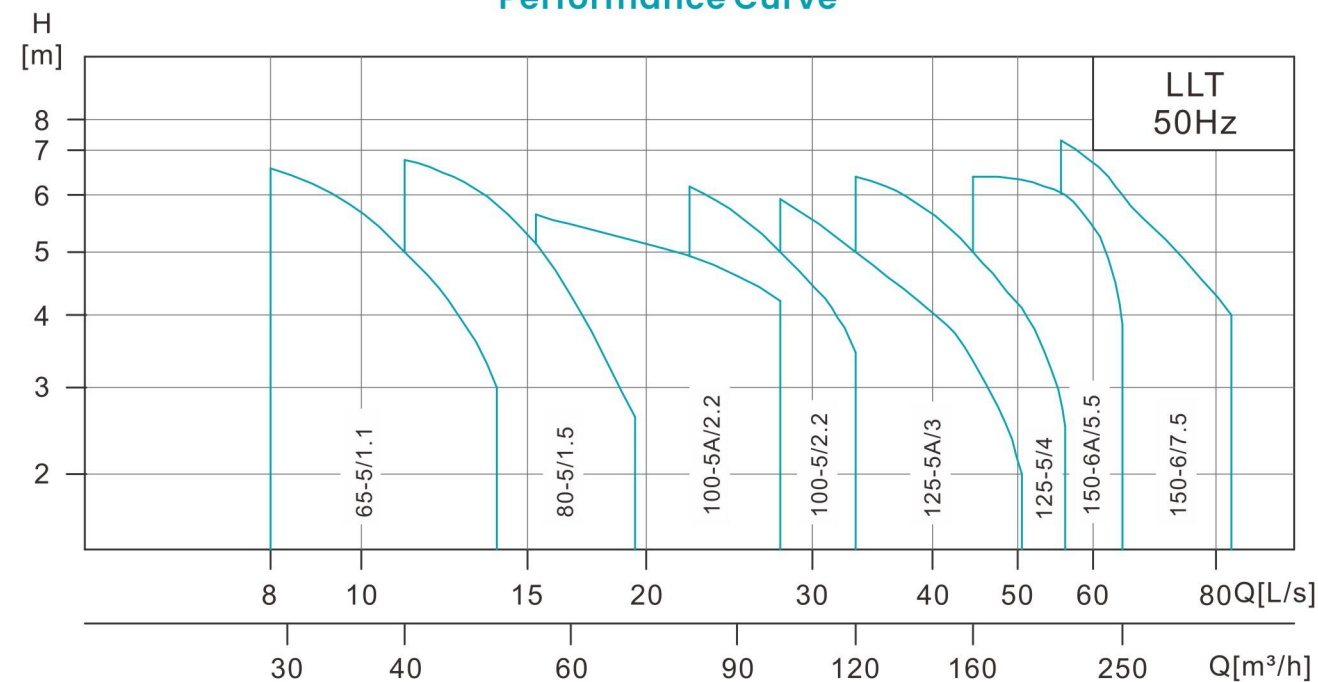

LLT Performance Parameter

No.	Model	Q[m³/h]	H[m]	Power[kW]	n[r/min]
1	LLT65-5/1.1	40	5	1.1	2900
2	LLT80-5/1.5	55	5	1.5	
3	LLT100-5A/2.2	80	5	2.2	
4	LLT100-5/2.2	100	5	2.2	1450
5	LLT125-5A/3	120	5	3	
6	LLT125-5/4	160	5	4	
7	LLT150-6A/5.5	200	6	5.5	
8	LLT150-6/7.5	250	6	7.5	

Structure Drawing Of LLT

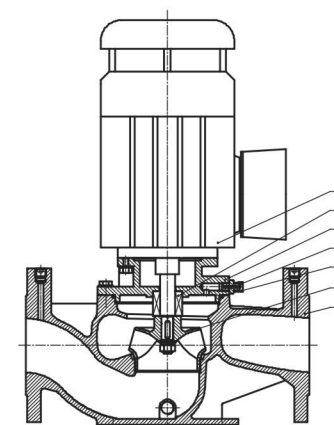

Material

No.	Name	Material	AISI/ASTM
1	Pump body	Cast iron HT200	ASTM25B
2	Impeller	Stainless steel ZG07Cr19Ni9	AISI304
3	O-ring	NBR	
4	Air release assembly	Assembly components	
5	Pump head	Cast iron HT200	ASTM25B
6	Knife edge mechanical seal	Tungsten carbide	
7	Electrical motor		

LLT Installation Dimension

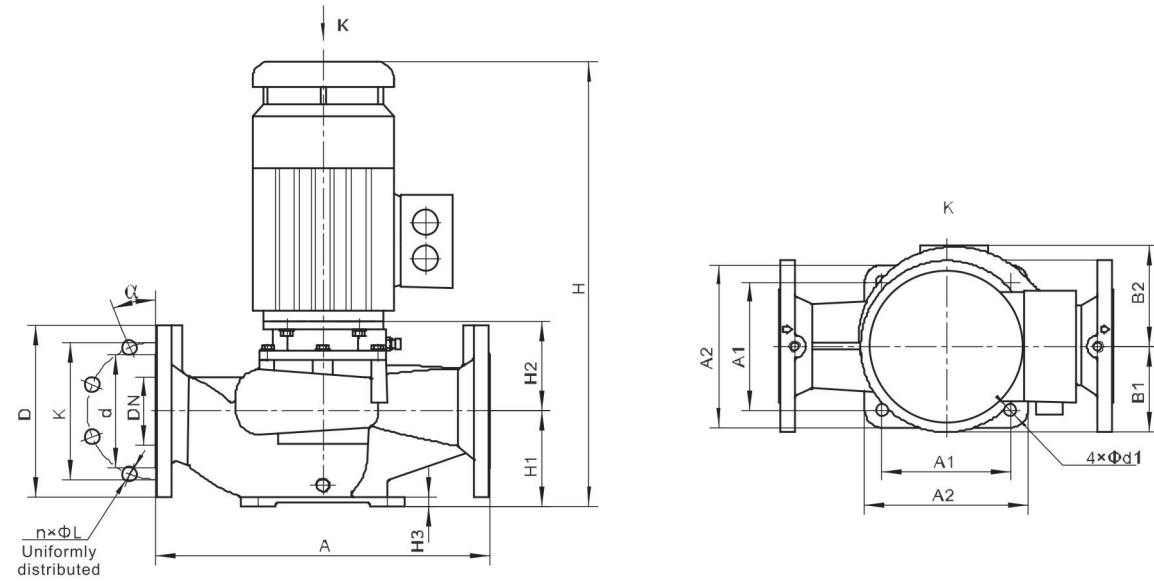

Model	Overall dimension				Installation dimension							Inlet and outlet flange dimension						Weight (kg)
	A	B1	B2	H	A1	A2	d1	H1	H2	H3	DN	d	K	D	α	n x L		
LLT65-5/1.1	340	100	110	490	130	170	15	100	105	12	65	118	145	185	45	4 x 18	32	
LLT80-5/1.5	390	100	120	545	150	190	15	112	105	12	80	132	160	200	22.5	8 x 18	39	

LLT Performance Table

Model	Q[m³/h]	30	35	40	45	50	55	60	65	70
LLT65-5/1.1	H(m)	6.6	5.9	5.0	4.3	3.1				
LLT80-5/1.5				6.9	6.4	5.8	5.0	4.3	3.4	2.8

LLT Performance Curve

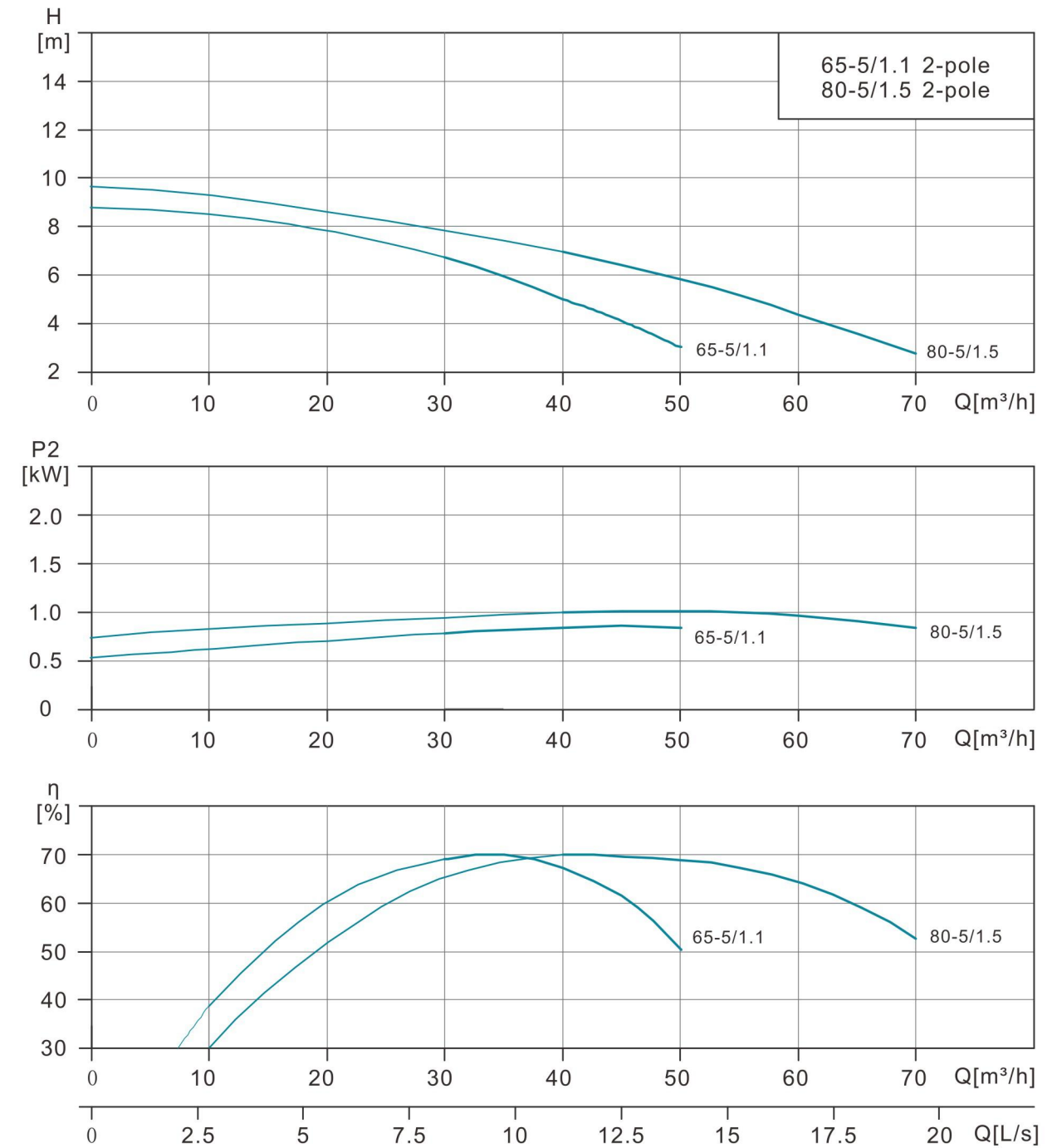

LLT Installation Dimension

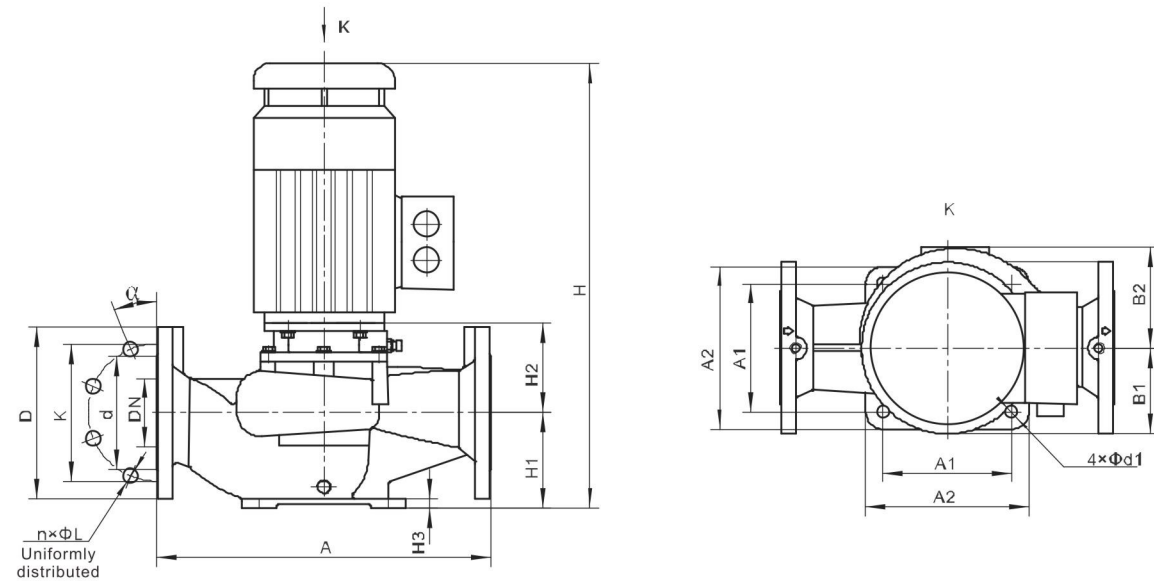

Model	Overall dimension				Installation dimension						Inlet and outlet flange dimension						Weight (kg)
	A	B1	B2	H	A1	A2	d1	H1	H2	H3	DN	d	K	D	α	n x L	
LLT100-5/2.2	560	130	173	702	160	200	15	170	110	30	100	156	180	220	22.5	8 x 18	66
LLT100-5A/2.2	560	130	173	702	160	200	15	170	110	30	100	156	180	220	22.5	8 x 18	66

LLT Performance Table

Model	Q[m ³ /h]	55	60	70	80	90	100	110	120
LLT100-5/2.2	H(m)				6.1	5.6	5.0	4.4	3.5
LLT100-5A/2.2		5.7	5.5	5.2	5.0	4.6	4.2		

LLT Performance Curve

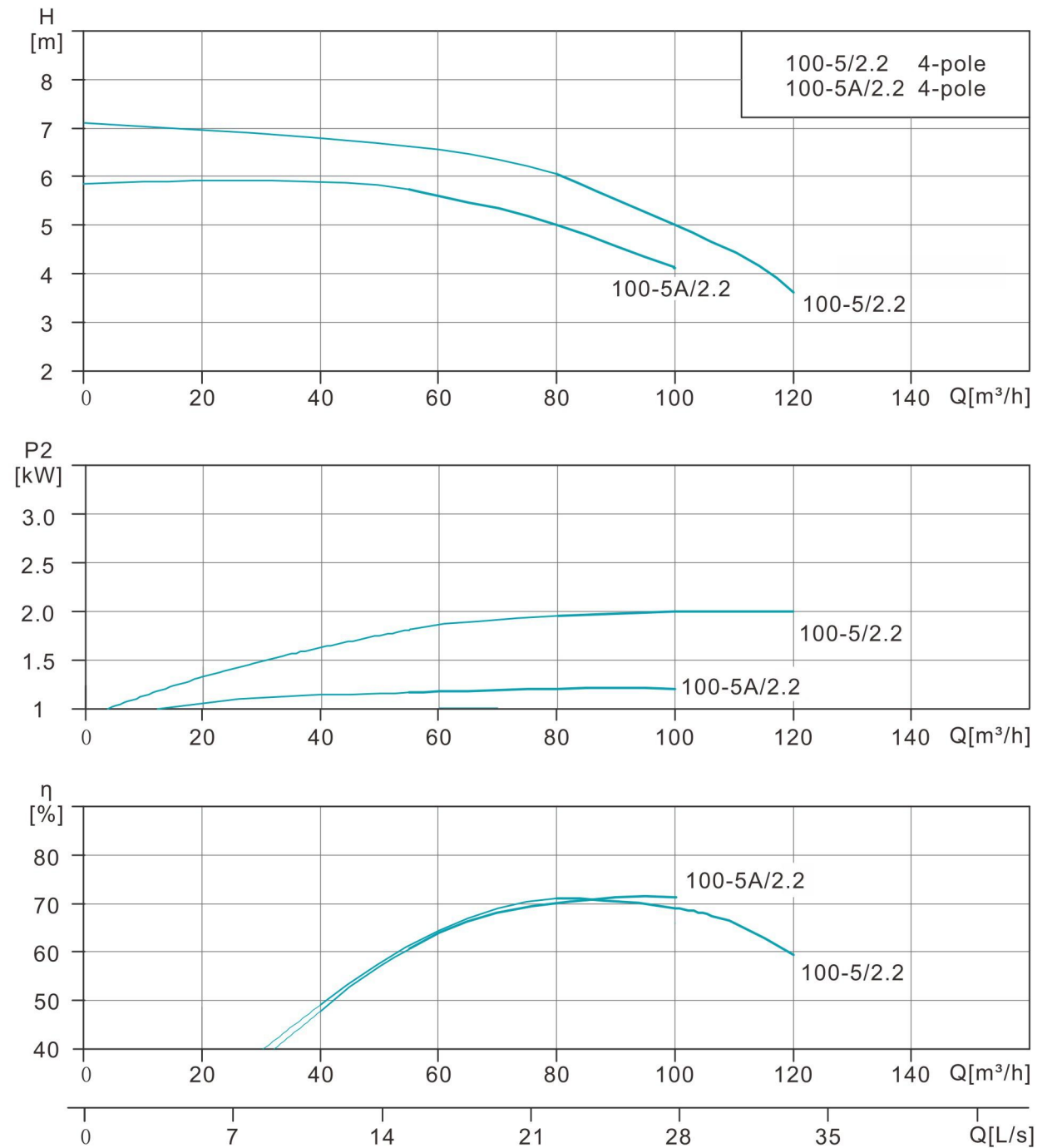

LLT Installation Dimension

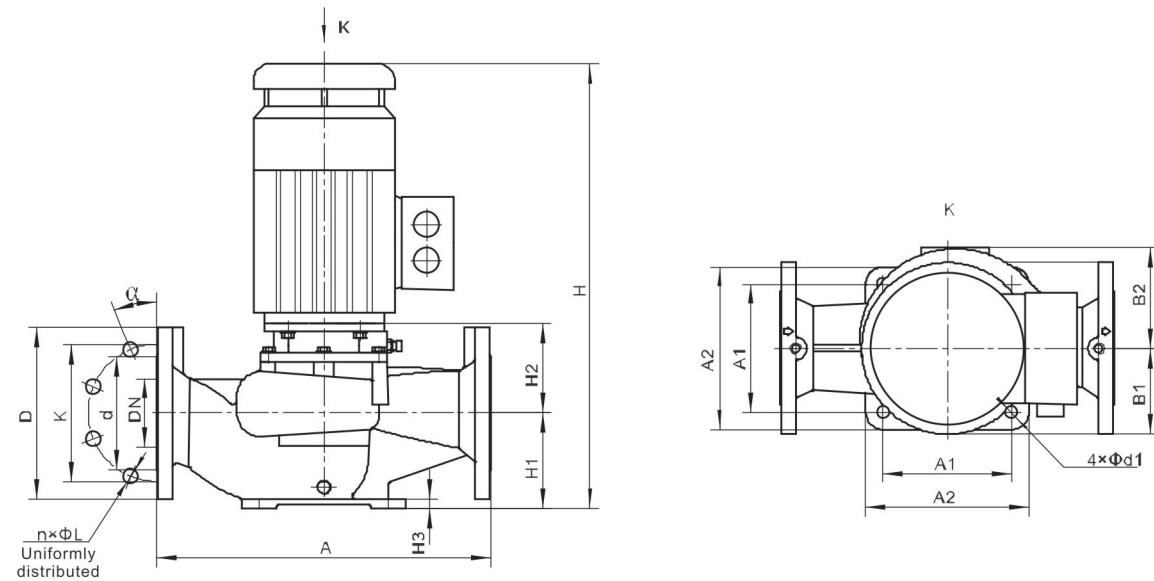

Model	Overall dimension				Installation dimension						Inlet and outlet flange dimension						Weight (kg)
	A	B1	B2	H	A1	A2	d1	H1	H2	H3	DN	d	K	D	α	n x L	
LLT125-5A/3	560	145	195	732	200	240	15	170	140	30	125	184	210	250	22.5	8 x 18	72
LLT125-5/4	560	145	195	731	200	240	15	170	140	30	125	184	210	250	22.5	8 x 18	83

LLT Performance Table

Model	Q[m³/h]	100	110	120	130	140	150	160	170	180	190	200
LLT125-5A/3	H(m)	5.9	5.5	5.0	4.3	4.2	3.9	3.4	2.9	2.3		
LLT125-5/4				6.5	6.1	5.7	5.2	5.0	4.3	4.1	3.7	2.7

LLT Performance Curve

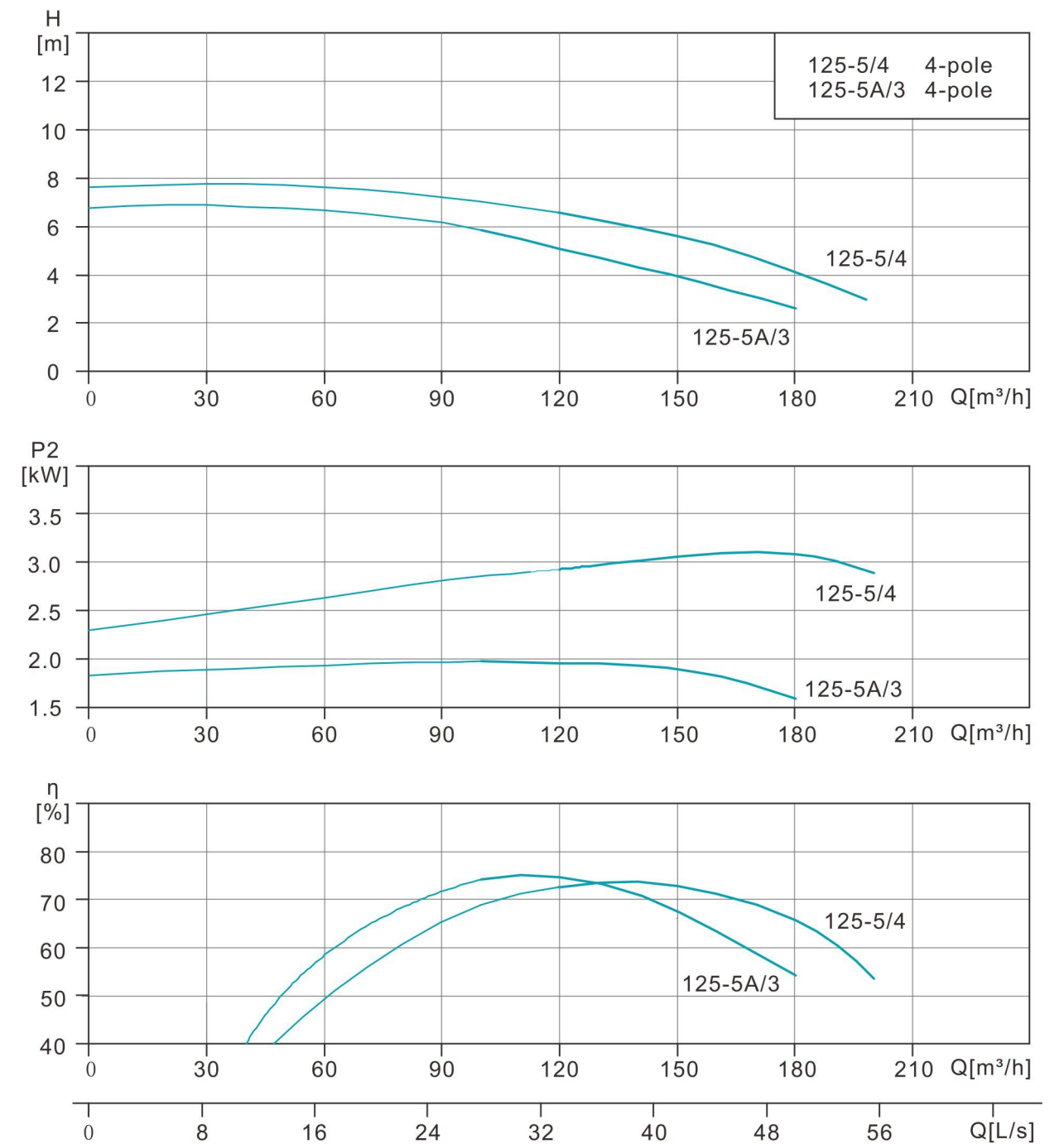

LLT Installation Dimension

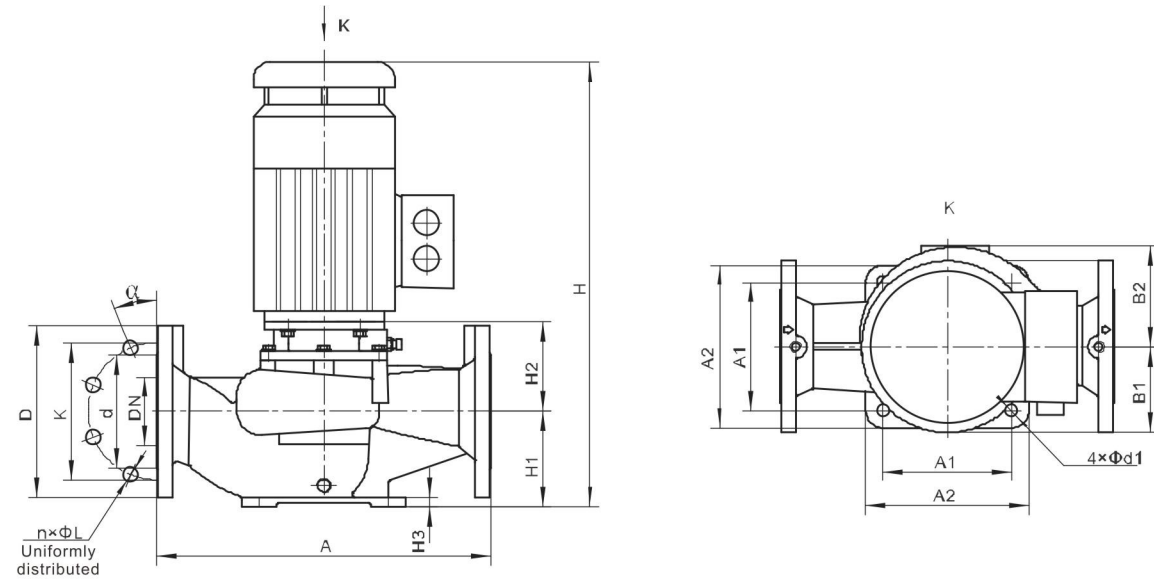

Model	Overall dimension				Installation dimension						Inlet and outlet flange dimension						Weight (kg)
	A	B1	B2	H	A1	A2	d1	H1	H2	H3	DN	d	K	D	α	n x L	
LLT150-6A/5.5	720	175	232	765	260	300	15	200	120	18	150	200	225	265	22.5	8 x 18	133
LLT150-6/7.5	720	175	232	803	260	300	15	200	120	18	150	200	225	265	22.5	8 x 18	145

LLT Performance Table

Model	Q[m³/h]	160	170	180	190	200	210	220	230	250	270	280	300
LLT150-6A/5.5	H(m)	6.5	6.4	6.3	6.1	6.0	5.8	5.3	4.9	3.9			
LLT150-6/7.5							7.4	6.9	6.3	6.0	5.1	4.6	4.0

LLT Performance Curve

