



## EZS Stainless Steel Horizontal Centrifugal Pump



### Application

EZS type stainless steel horizontal single stage centrifugal pump is a multifunctional product with a wide range of applications, which can deliver a variety of different media including water or industrial liquids, adapted to different temperature, flow and pressure range. Its typical applications mainly include the following aspects:

Water supply: water plant filtration, transmission and partition water supply and main pressurization.

Industrial pressurization: process water system, cleaning system.

Industrial liquid transmission: boiler water supply, condensation system, cooling and air conditioning system, machine tools, weak acid and alkali transmission.

Water treatment: distillation system or separator, swimming pool, etc.

Farmland irrigation, medicine and health care, etc.

### Installation Condition

EZS type stainless steel horizontal single-stage centrifugal pump is a pump shaft of direct connection, composed of pump, pump shaft and standard motor.

The pump shall be installed in a ventilated and antifreezing place. The installation of the pump should ensure that the pump is not affected by the tension of the system pipeline when using.

If the pump is installed outdoors, a suitable cover must be provided to prevent water intake or condensation of the electrical components.

In order to facilitate the inspection and maintenance, enough space must be left around the unit.

The electrical wiring device shall ensure that the pump is not damaged by phase deficiency, voltage instability, leakage and overload.

The pump shall be installed horizontally on the base, with the suction port of the pump oriented horizontally and the discharge outlet of the pump oriented vertically.

### Motor

The motor is a fully enclosed, air-cooled dipole standard motor

Protection level: IP55

Insulation class: F

Standard voltage: 50Hz 1X220V

3X380V

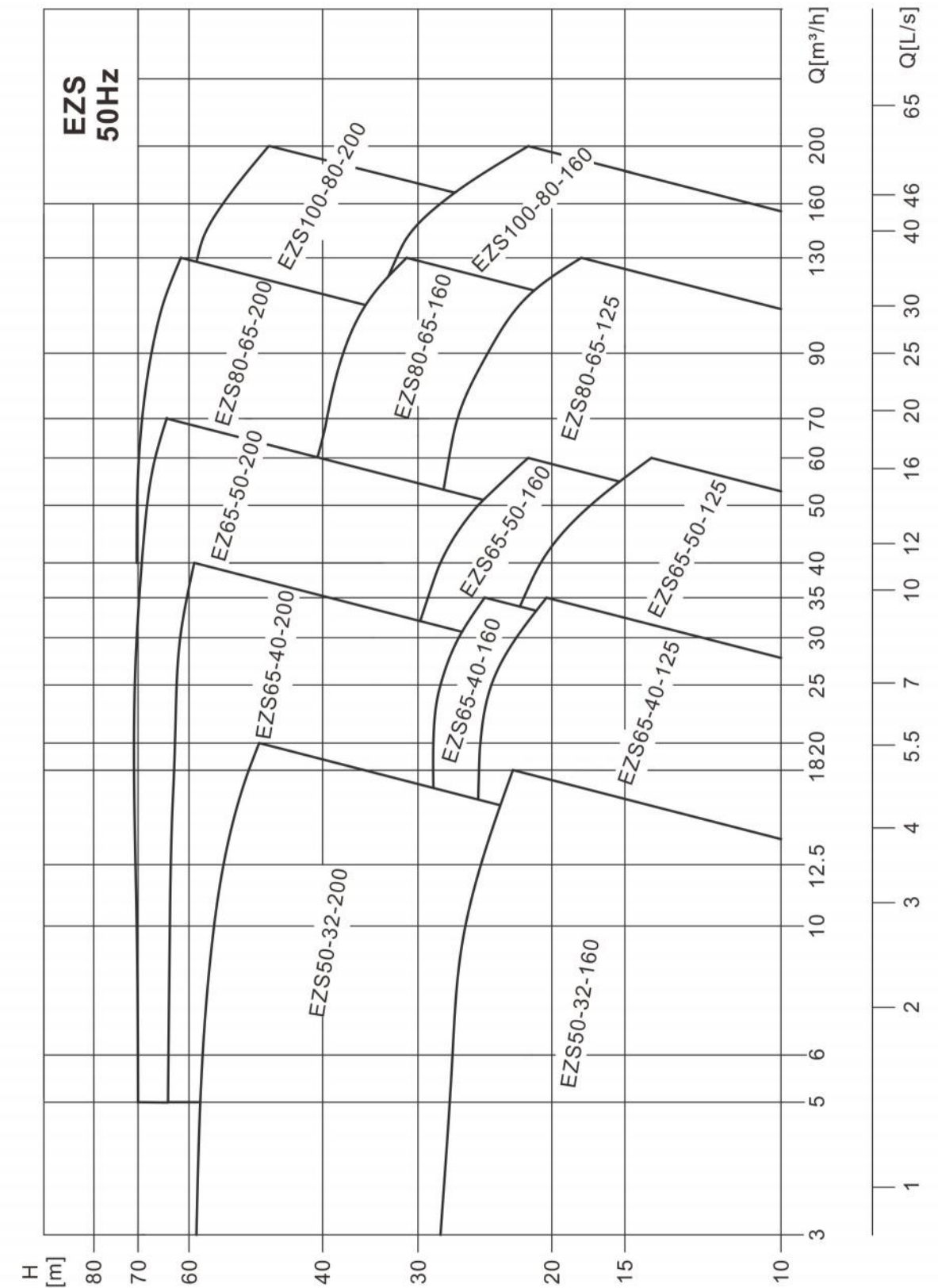

### Model Definition

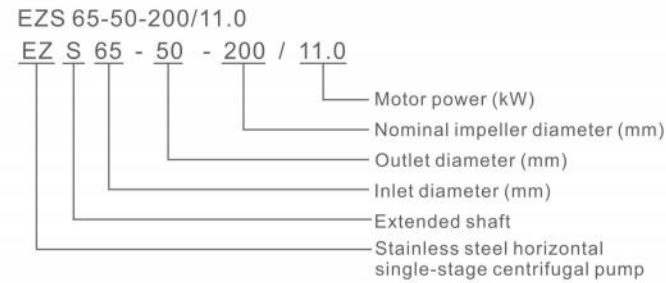

### Operating Condition

Clean, thin, non-flammable and explosive liquid that does not contain solid particles and fibers.  
 Liquid with a temperature between -20°C and 100°C.  
 Maximum ambient temperature + 40°C.  
 The highest altitude is 1,000 meters.  
 Maximum system pressure is 10 bar.

### Curve Condition

The following instructions apply to the curves shown later:

1. The curve tolerance meets the ISO9906, Appendix A.
2. All the curves are based on the measurement value of the voltage of 3X380V and the motor at a constant speed of 2900rpm or 2950rpm.
3. The test medium for the temperature of 20°C, without any solid impurities of water.
4. The pump shall not work at the minimum flow rate below the minimum specified in the curve or higher than the maximum flow rate specified in the curve.
5. If the viscosity or density of the pumped fluid is different from the water, the motor power must be adjusted.

### Minimum Inlet Pressure - NPSH

If the pressure in the pump is lower than the steam pressure conveying the liquid, cavitation may occur. In order to avoid cavitation, ensure a minimum pressure on the inlet side of the pump, and the maximum suction range H [m] can be calculated according to the following formula :

$$H = P_b \times 10.2 - NPSH - H_f - H_v - H_s$$

P<sub>b</sub> - atmospheric pressure (bar)

In a closed pipeline, it can be considered as the system pressure (bar) of a closed system.

NPSH net positive suction head (meters)

It can be read at the maximum flow rate corresponding to the NPSH curve in the performance curve.

H<sub>f</sub> - Pipeline loss at the inlet (meters)

The value corresponding to the maximum flow rate that the pipeline may generate.

H<sub>v</sub> - Vaporization pressure of liquid (meters)

The magnitude of its value depends on the temperature of the liquid and the vaporization pressure of the liquid.

H<sub>s</sub> - Safety margin (meters)

Minimum pressure head of 0.5 meters

By calculating, if 'H' is positive, the pump can operate with the maximum suction range of 'H', the pump must operate normally with an inlet head with a minimum pressure of 'H' meters.

Note : Generally, the above calculation is not carried out.

'H' is calculated only when the pump is used if :

1. The liquid temperature is relatively high
2. The liquid flow rate exceeds the rated value
3. Large suction range or long inlet pipeline
4. The system pressure is too small
5. Poor import conditions

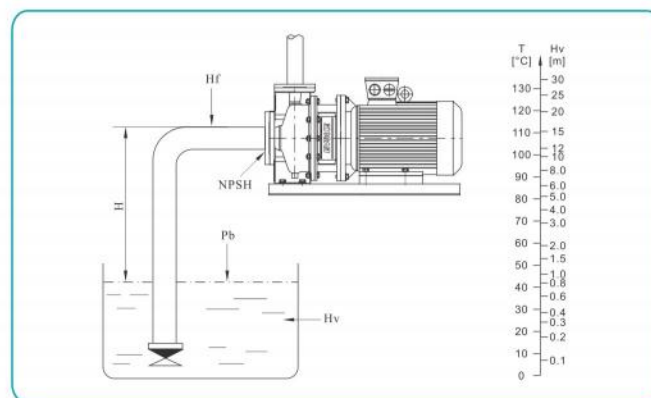

### Performance Table

	Model	Q[m³/h]	H [m]	n[r/min]	Standard Motor Voltage [V]		
					1×220V	3×380V	
					P2 [kW]	P2 [kW]	
1	EZS50-32-160/1.1	6.3	18	2900	1.1	1.1	
2	EZS50-32-160/1.5	12.5	20		1.5	1.5	
3	EZS50-32-160/2.2	12.5	25		2.2	2.2	
4	EZS50-32-200/3.0	12.5	32			3	
5	EZS50-32-200/4.0	12.5	42			4	
6	EZS50-32-200/5.5	12.5	54			5.5	
7	EZS65-40-125/1.5	25	13		1.5	1.5	
8	EZS65-40-125/2.2	25	18		2.2	2.2	
9	EZS65-40-125/3.0	25	24			3	
10	EZS65-40-160/4.0	25	28			4	
11	EZS65-40-200/5.5	25	36			5.5	
12	EZS65-40-200/7.5	25	46			7.5	
13	EZS65-40-200/11.0	25	62	2950		11	
14	EZS65-50-125/3.0	50	13	2900		3	
15	EZS65-50-125/4.0	50	18			4	
16	EZS65-50-160/5.5	50	25		2900		5.5
17	EZS65-50-200/7.5	50	32			7.5	
18	EZS65-50-200/9.2	50	40			9.2	
19	EZS65-50-200/11.0	50	48			11	
20	EZS65-50-200/15.0	50	58		2950		15
21	EZS65-50-200/18.5	50	68			18.5	
22	EZS80-65-125/5.5	100	13		2900		5.5
23	EZS80-65-125/7.5	100	18				7.5
24	EZS80-65-125/9.2	100	23				9.2
25	EZS80-65-160/11.0	100	27				11
26	EZS80-65-160/15.0	100	36			15	
27	EZS80-65-200/18.5	100	45			18.5	
28	EZS80-65-200/22.0	100	53			22	
29	EZS80-65-200/30.0	100	66			30	
30	EZS100-80-160/11.0	160	15	2950			11
31	EZS100-80-160/15.0	160	22			15	
32	EZS100-80-160/18.5	160	28			18.5	
33	EZS100-80-200/22.0	160	33			22	
34	EZS100-80-200/30.0	160	45		30		
35	EZS100-80-200/37.0	160	54		37		

### Structure Drawing

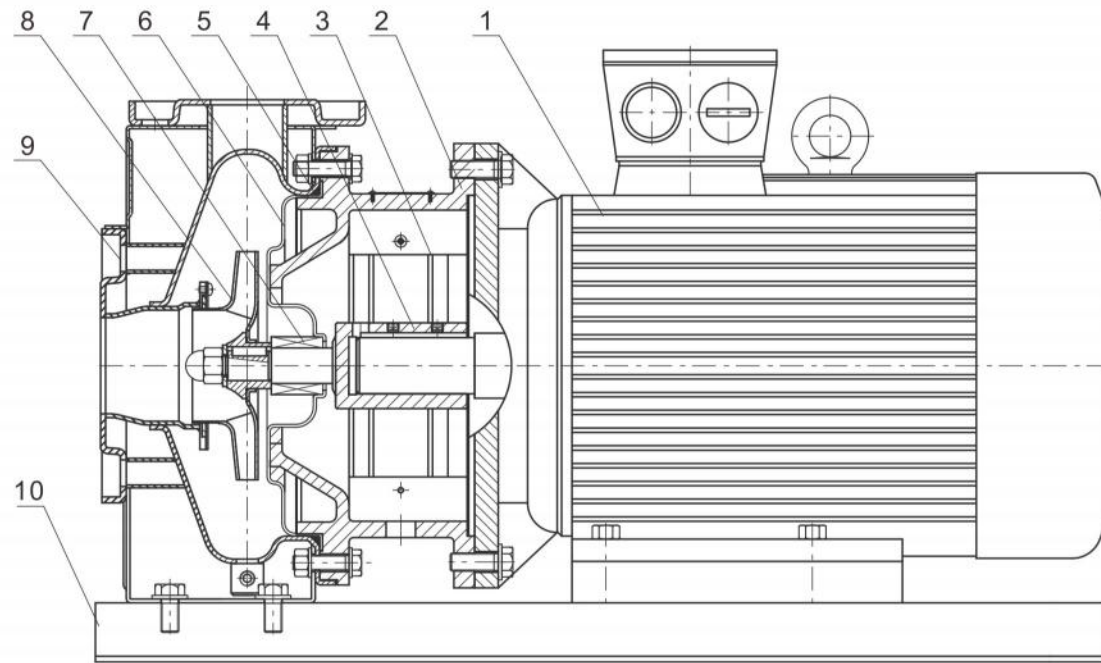

### Installation Dimension

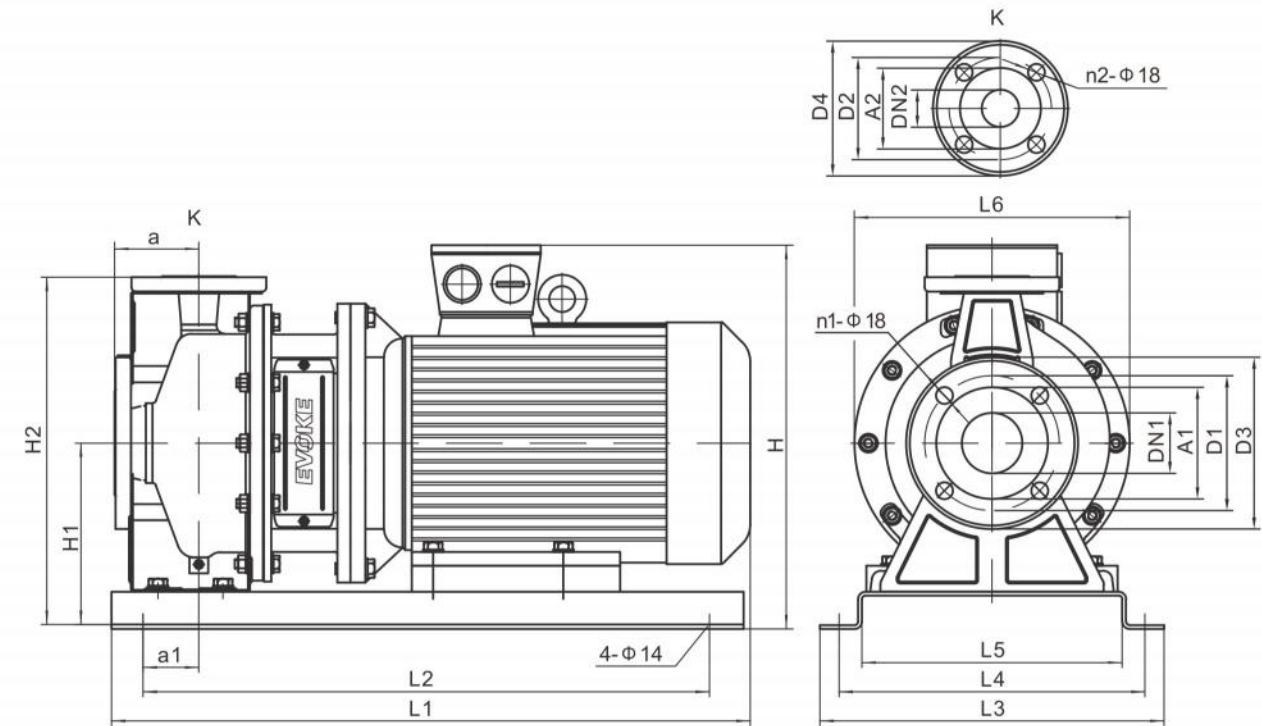

### Parts Material

No.	Name	Material	Code/ AISI /ASTM
1	Motor		
2	Pump head	Cast-iron HT 200	ASTM25B
3	Safety guard	Stainless steel, 0Cr18Ni9	AISI304
4	Shaft	Stainless steel 2Cr13/0Cr 18Ni9	AISI420/AISI304
5	Rubber parts	NBR	
6	Pump head lining	Stainless steel 0Cr18Ni9	AISI304
7	Mechanical seal	Graphite/silicon carbide	
8	Impeller	Stainless steel 0Cr18Ni9	AISI304
9	Pump body	Stainless steel 0Cr18Ni9	AISI304
10	Baseplate	Steel Q235	ASTMA570

### Dimension And Weight

Model	Dimension [mm]																Weight [kg]					
	DN1	DN2	A1	A2	D1	D2	D3	D4	n1	n2	a	a1	H	H1	H2	L1		L2	L3	L4	L5	L6
EZS50-32-160/1.1	50	32	98	75	125	100	160	139	4	4	80	32	290	152	296	470	370	280	240	192	210	31
EZS50-32-160/1.5	50	32	98	75	125	100	160	139	4	4	80	46	307	152	296	500	430	280	240	192	210	37
EZS50-32-160/2.2	50	32	98	75	125	100	160	139	4	4	80	46	307	152	296	500	430	280	240	192	210	39
EZS50-32-200/3.0	50	32	98	75	125	100	160	139	4	4	84	42	370	200	386	550	460	330	290	242	300	53
EZS50-32-200/4.0	50	32	98	75	125	100	160	139	4	4	84	47	393	200	386	560	480	330	290	242	300	58
EZS50-32-200/5.5	50	32	98	75	125	100	160	139	4	4	84	50	413	200	386	660	580	370	330	280	300	77
EZS65-40-125/1.5	65	40	118	84	145	110	185	145	4	4	80	45	307	152	294	502	430	280	240	192	210	33
EZS65-40-125/2.2	65	40	118	84	145	110	185	145	4	4	80	45	307	152	294	502	430	280	240	192	210	35
EZS65-40-125/3.0	65	40	118	84	145	110	185	145	4	4	80	45	322	152	294	532	460	300	260	212	250	47
EZS65-40-160/4.0	65	40	118	84	145	110	185	145	4	4	80	45	345	152	294	557	480	330	290	242	250	52
EZS65-40-200/5.5	65	40	118	84	145	110	185	145	4	4	100	50	413	200	380	680	580	370	330	280	300	78
EZS65-40-200/7.5	65	40	118	84	145	110	185	145	4	4	100	50	413	200	380	680	580	370	330	280	300	82
EZS65-40-200/11.0	65	40	118	84	145	110	185	145	4	4	100	50	456	200	380	790	690	420	380	330	350	161

### Dimension And Weight

Model	Dimension [mm]																		Weight [kg]			
	DN1	DN2	A1	A2	D1	D2	D3	D4	n1	n2	a	a1	H	H1	H2	L1	L2	L3		L4	L5	L6
EZS65-50-125/3.0	65	50	118	98	145	125	185	160	4	4	86	45	342	172	338	548	468	330	290	242	250	49
EZS65-50-125/4.0	65	50	118	98	145	125	185	160	4	4	86	45	365	172	338	570	490	330	290	242	250	54
EZS65-50-160/5.5	65	50	118	98	145	125	185	160	4	4	100	50	413	200	380	680	580	370	330	280	300	78
EZS65-50-200/7.5	65	50	118	98	145	125	185	160	4	4	100	50	413	200	380	680	580	370	330	280	300	82
EZS65-50-200/9.2	65	50	118	98	145	125	185	160	4	4	100	50	413	200	380	680	580	370	330	280	300	85
EZS65-50-200/11.0	65	50	118	98	145	125	185	160	4	4	100	50	456	200	380	790	690	420	380	330	350	161
EZS65-50-200/15.0	65	50	118	98	145	125	185	160	4	4	100	50	456	200	380	790	690	420	380	330	350	171
EZS65-50-200/18.5	65	50	118	98	145	125	185	160	4	4	100	50	456	200	380	830	730	420	380	330	350	188
EZS80-65-125/5.5	80	65	130	118	160	145	200	185	8	4	100	50	413	200	380	690	590	370	330	280	300	79
EZS80-65-125/7.5	80	65	130	118	160	145	200	185	8	4	100	50	413	200	380	690	590	370	330	280	300	83
EZS80-65-125/9.2	80	65	130	118	160	145	200	185	8	4	100	50	413	200	380	690	590	370	330	280	300	87
EZS80-65-160/11.0	80	65	130	118	160	145	200	185	8	4	100	50	456	200	400	790	690	420	380	330	350	163
EZS80-65-160/15.0	80	65	130	118	160	145	200	185	8	4	100	50	456	200	400	790	690	420	380	330	350	173
EZS80-65-200/18.5	80	65	130	118	160	145	200	185	8	4	100	50	476	220	445	830	730	420	380	330	350	190
EZS80-65-200/22.0	80	65	130	118	160	145	200	185	8	4	100	50	500	220	445	880	780	455	415	365	350	220
EZS80-65-200/30.0	80	65	130	118	160	145	200	185	8	4	100	50	550	240	465	950	850	495	455	405	400	292
EZS100-80-160/11.0	100	80	150	130	180	160	220	200	8	8	125	75	476	220	445	830	730	420	380	330	350	163
EZS100-80-160/15.0	100	80	150	130	180	160	220	200	8	8	125	75	476	220	445	830	730	420	380	330	350	173
EZS100-80-160/18.5	100	80	150	130	180	160	220	200	8	8	125	75	476	220	445	870	770	420	380	330	350	185
EZS100-80-200/22.0	100	80	150	130	180	160	220	200	8	8	125	75	500	220	470	915	810	455	415	365	350	223
EZS100-80-200/30.0	100	80	150	130	180	160	220	200	8	8	125	75	550	240	490	985	880	495	455	405	400	295
EZS100-80-200/37.0	100	80	150	130	180	160	220	200	8	8	125	75	550	240	490	985	880	495	455	405	400	315

### EZS50-32-\*\*\*:

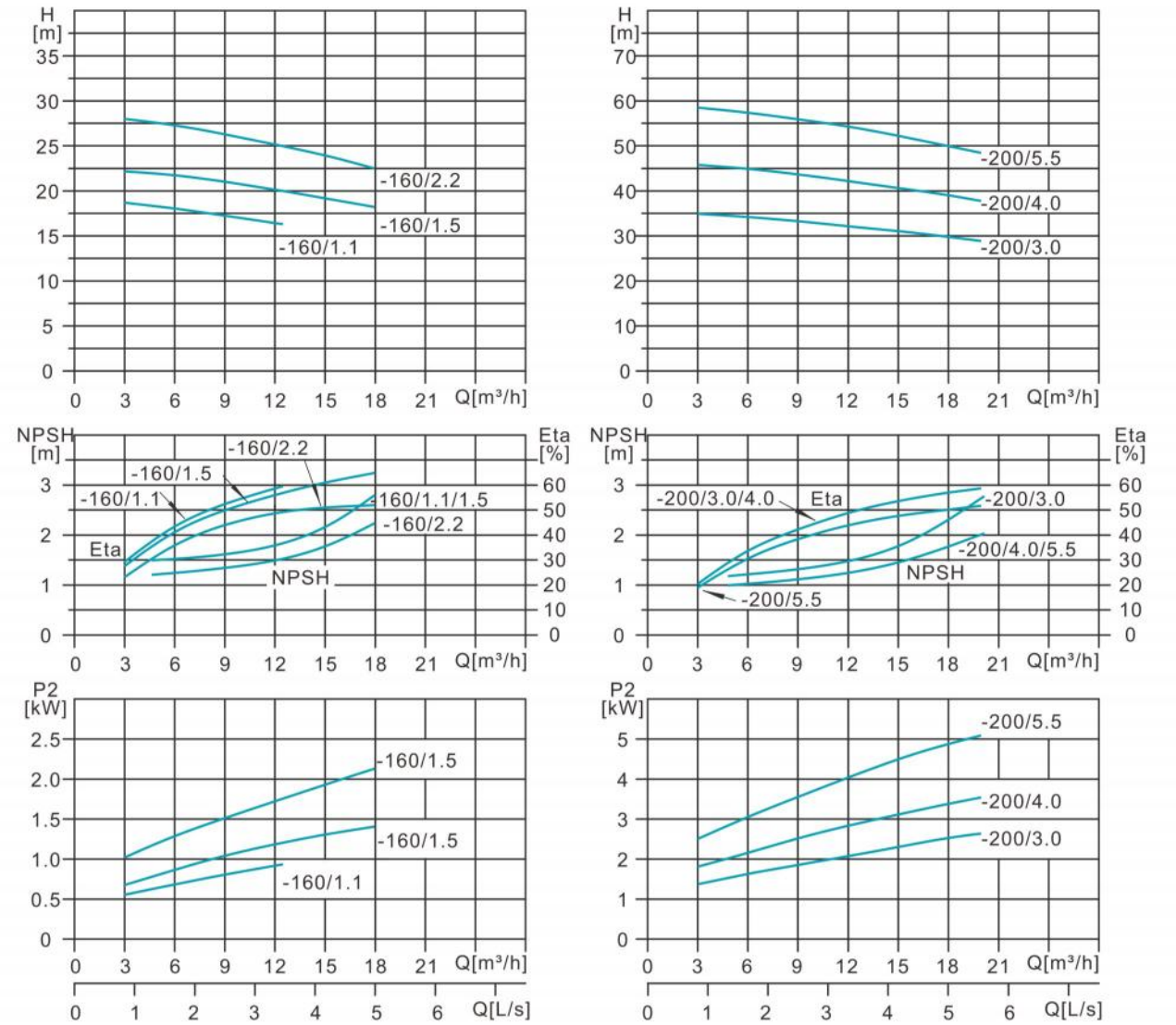

### Performance Table

Model	Power (kW)	Q(m³/h)	3	6.3	9	12.5	15	18	20
EZS50-32-160/1.1	1.1	H (m)	18.7	18	17.2	16.4			
EZS50-32-160/1.5	1.5		22.5	22	21	20	19	18	
EZS50-32-160/2.2	2.2		28	27	26.3	25	24	22.5	
EZS50-32-200/3.0	3		34.9	34.1	33.3	32	31	29.8	28.9
EZS50-32-200/4.0	4		45.7	44.8	43.7	42	40.7	39	37.7
EZS50-32-200/5.5	5.5		58.5	57.2	56	54	52.5	50	48.5

### EZS65-40-\*\*\*:

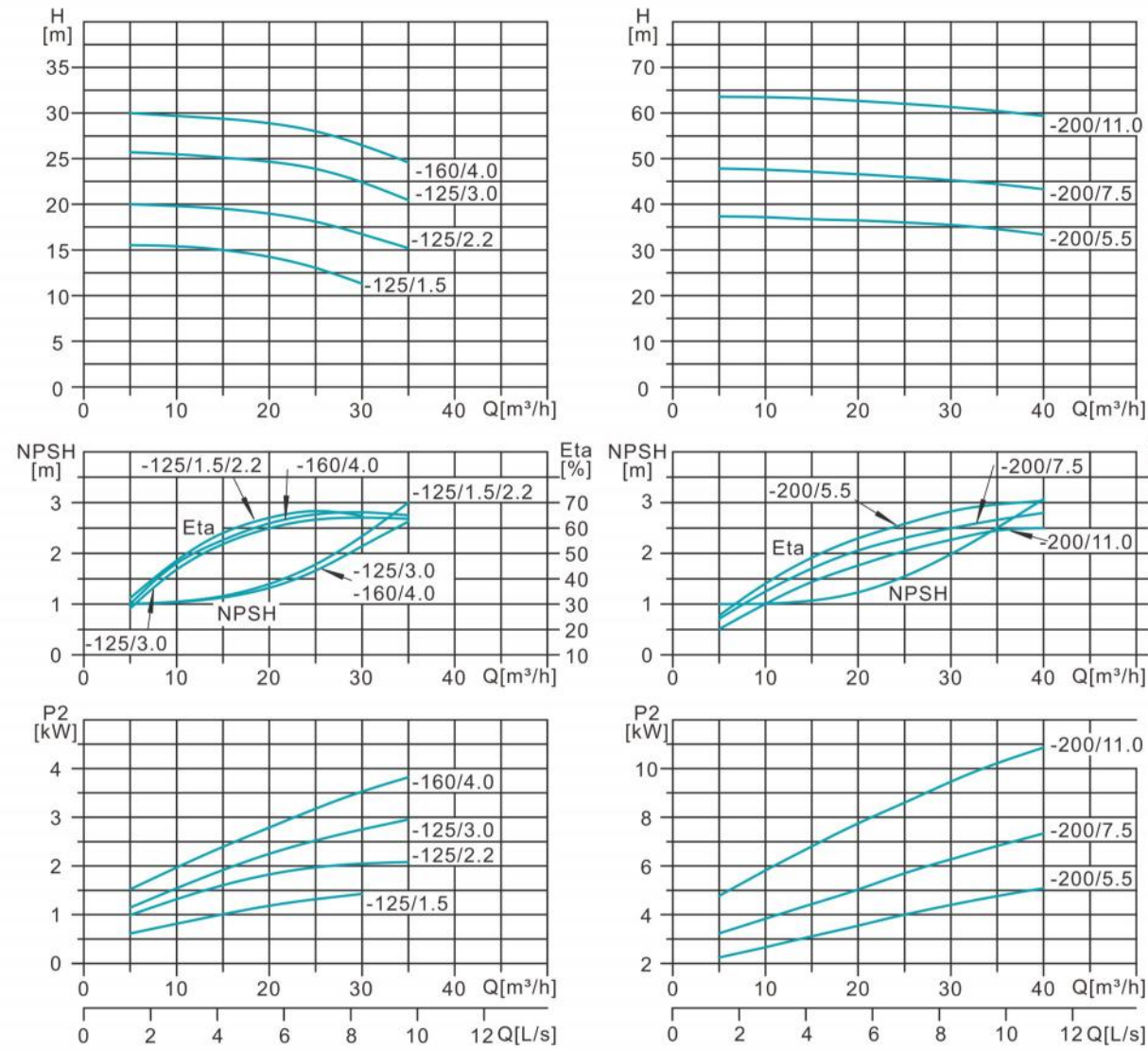

### Performance Table

Model	Power (kW)	Q(m³/h)	5	10	15	20	25	30	35	40
EZS65-40-125/1.5	1.5	H (m)	15.5	15.4	15	14.4	13	11.3		
EZS65-40-125/2.2	2.2		20	19.7	19.5	19	18	16.7	15.2	
EZS65-40-125/3.0	3		25.7	25.3	25.1	24.8	24	22.3	20.3	
EZS65-40-160/4.0	4		30	29.7	29.3	28.9	28	26.5	24.5	
EZS65-40-200/5.5	5.5		37.4	37.2	36.7	36.4	36	35.5	34.6	33.3
EZS65-40-200/7.5	7.5		48	47.5	47	46.6	46	45.2	44.5	43.3
EZS65-40-200/11.0	11		64	63.5	63	62.5	62	61.5	60.5	59

### EZS65-50-\*\*\*:

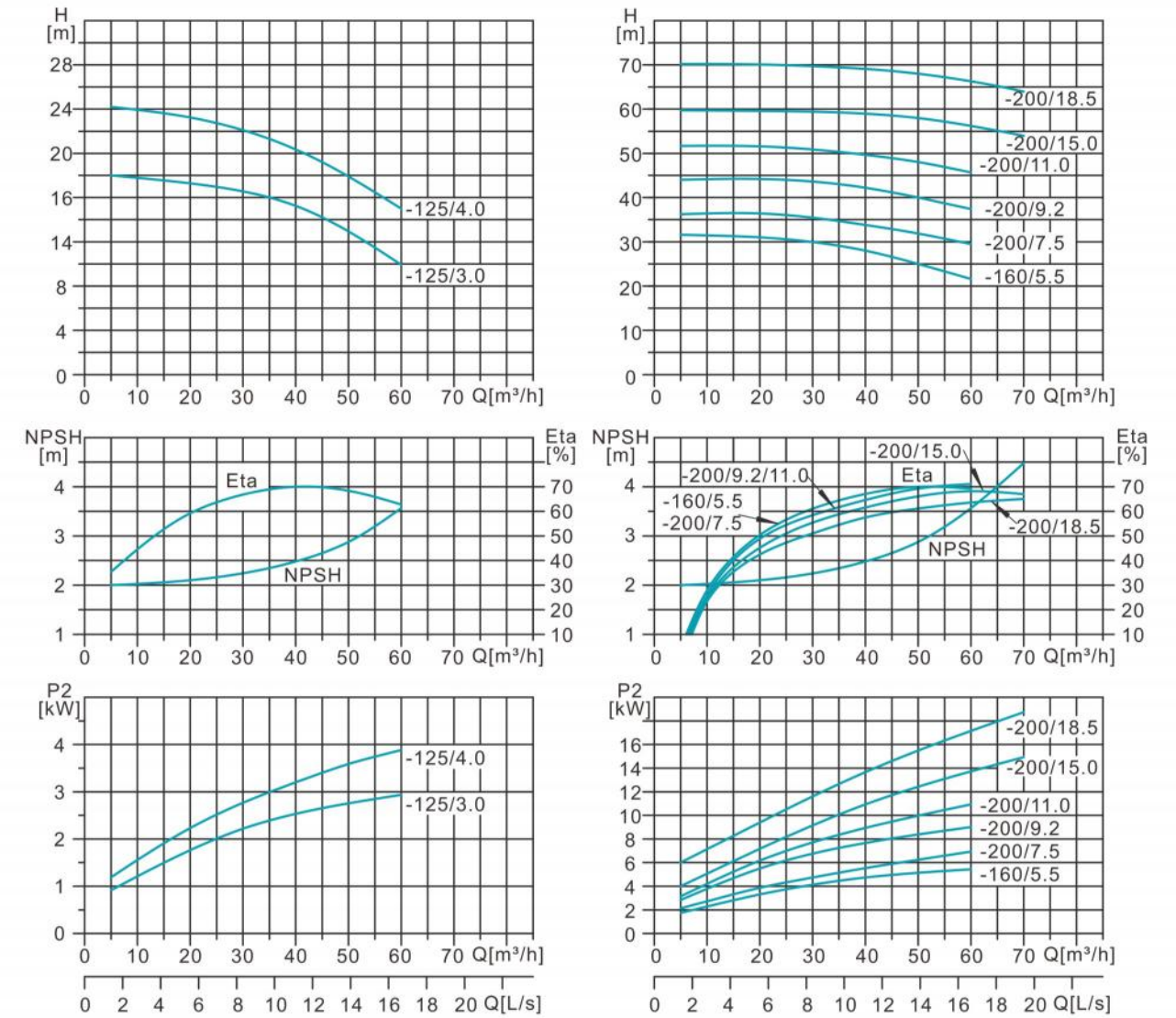

### Performance Table

Model	Power (kW)	Q(m³/h)	5	10	20	30	40	50	60	70
EZS65-50-125/3.0	3	H (m)	18	17.8	17.2	16.4	15.1	13	10	
EZS65-50-125/4.0	4		24.2	24.2	23.6	22.6	20.7	18	14.8	
EZS65-50-160/5.5	5.5		31.6	31.5	31	30	28	25	21.5	
EZS65-50-200/7.5	7.5		36.3	36.6	36.4	35.6	34.1	32	29.6	
EZS65-50-200/9.2	9.2		43.5	43.5	43.5	43	42	40	37.5	
EZS65-50-200/11.0	11		51.5	51.5	51	50	49.3	48	45.6	
EZS65-50-200/15.0	15		59.7	59.7	59.6	59.5	59	58	56.2	53
EZS65-50-200/18.5	18.5		70.2	70.2	70.1	70	69.1	68	66.4	64

**EZS80-65-\*\*\*:**

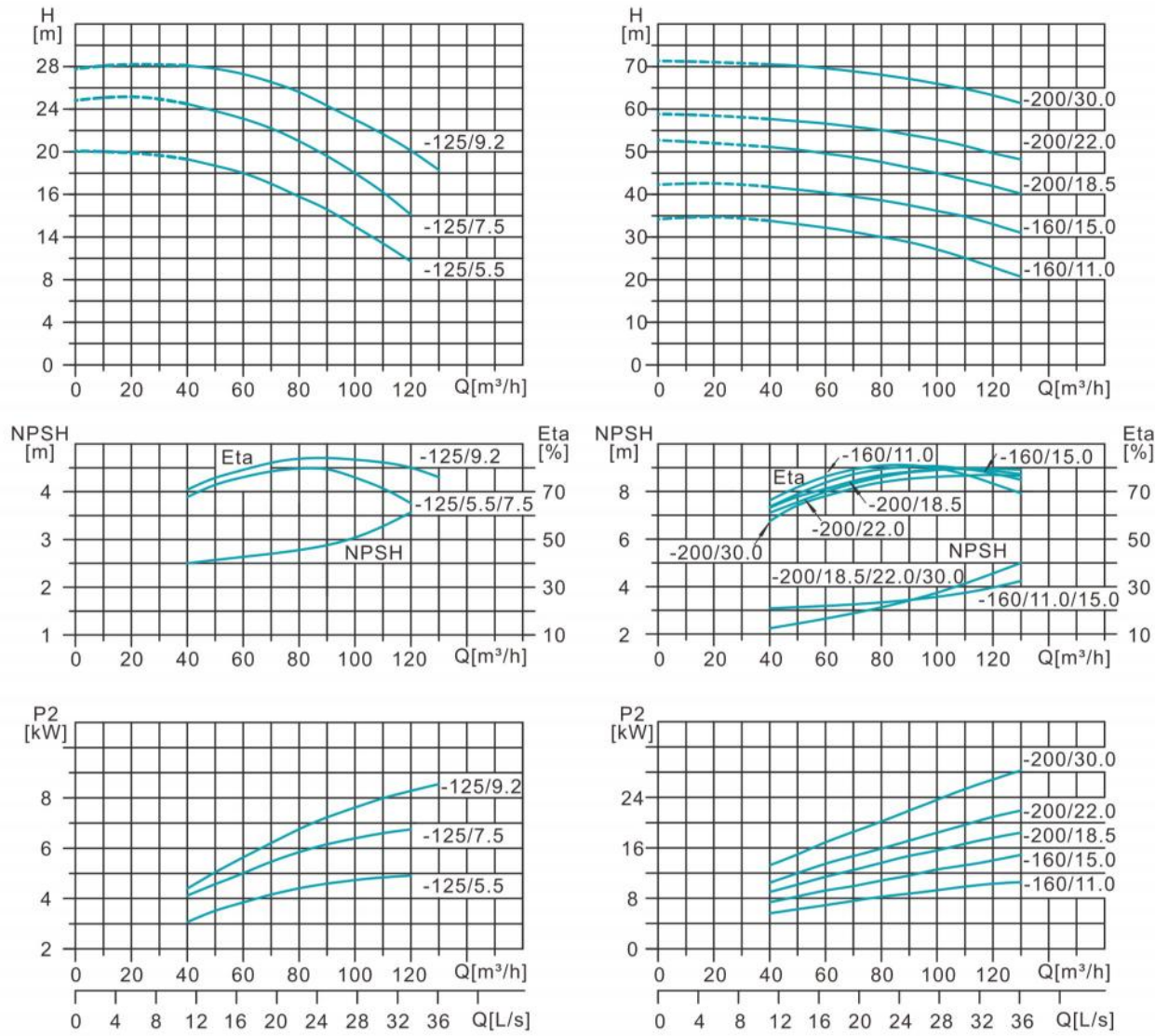

**Performance Table**

Model	Power (kW)	Q(m³/h)	40	50	60	70	80	90	100	110	120	130
EZS80-65-125/5.5	5.5	H (m)	19.3	18.7	18	17	15.8	14.8	13	11.4	9.7	
EZS80-65-125/7.5	7.5		24.5	23.8	23.1	22.2	21	19.6	18	16.2	14.1	
EZS80-65-125/9.2	9.2		28.1	27.8	27.3	26.6	25.7	24.3	23	21.8	20.1	18.3
EZS80-65-160/11.0	11.0		33.9	33	32.2	31.3	29.9	28.8	27	25.1	22.9	20.7
EZS80-65-160/15.0	15.0		41.8	41.1	40.4	39.5	38.6	37.6	36	34.8	33	31
EZS80-65-200/18.5	18.5		51	50.5	49.6	48.7	47.6	46.3	45	43.5	42.2	40.2
EZS80-65-200/22.0	22.0		57.7	57.2	56.8	55.9	55.1	54	53	51.6	49.7	48.2
EZS80-65-200/30.0	30.0		70.2	70.2	69.6	68.9	68.2	67.1	66	64.6	63.3	61.4

**EZS100-80-\*\*\*:**

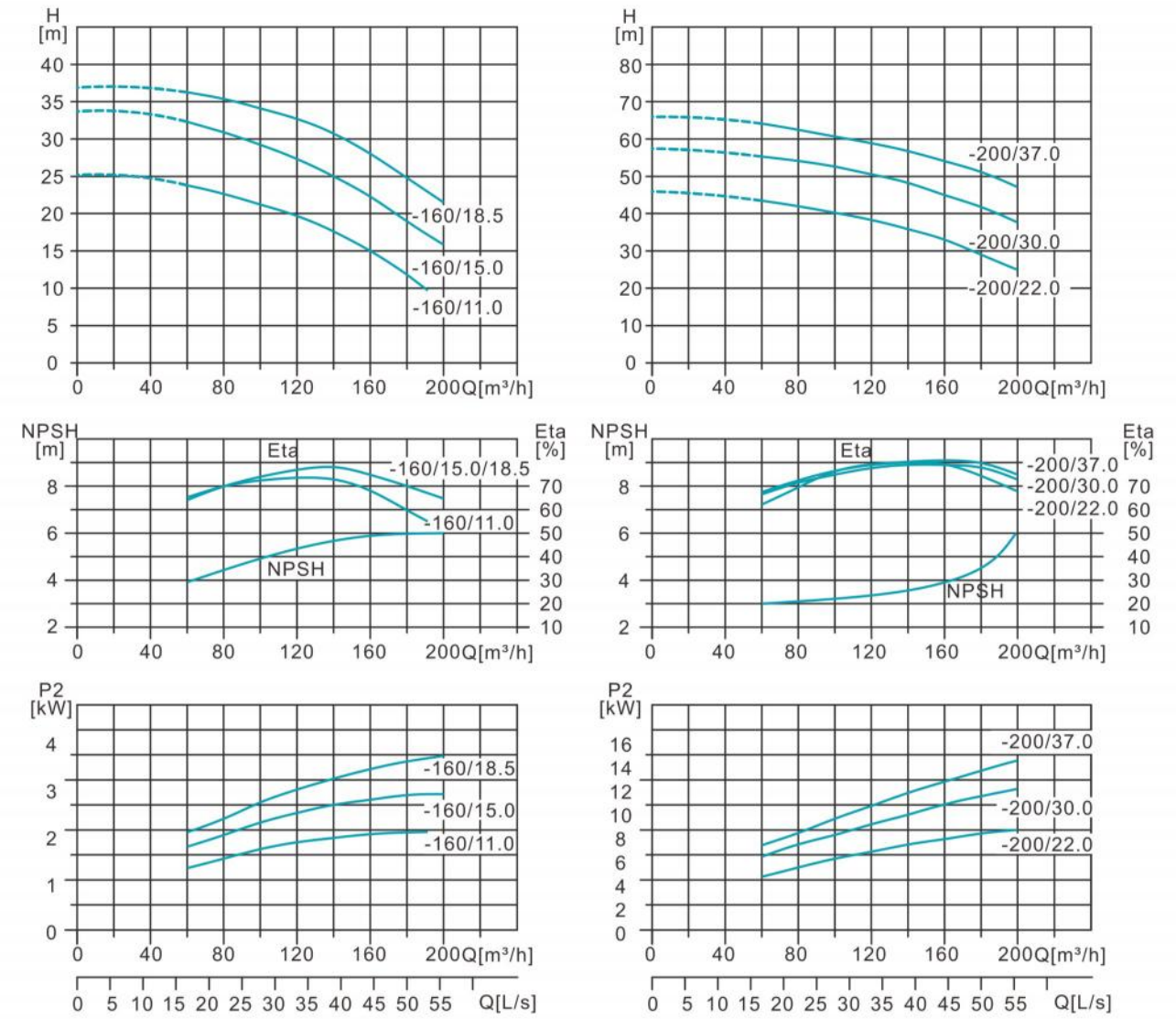

**Performance Table**

Model	Power (kW)	Q(m³/h)	60	80	100	120	140	160	180	192	200
EZS100-80-160/11.0	11	H (m)	23.8	22.7	21.1	19.7	17.6	15	11.8	9.7	
EZS100-80-160/15.0	15		32.3	30.8	29.1	27.2	25.1	22	18.8	16.7	16.1
EZS100-80-160/18.5	18.5		36.2	35.2	33.8	32.7	31	28	24.8	22.3	21.5
EZS100-80-200/22.0	22		43.5	42	39.7	38.3	35.9	33	29	26.7	24.9
EZS100-80-200/30.0	30		55.4	54.1	52.6	50.5	48.2	45	41.9	38.2	37.6
EZS100-80-200/37.0	37		64.1	62.5	61	59	57.4	54	51.2	47.6	47.1