



# EPH/EPV Horizontal/Vertical Pipeline Pump



## Application

EPV/EPH vertical pipeline centrifugal pump is used for transporting water and other liquids with physical and chemical properties similar to water. It is suitable for industrial and urban water supply and drainage, pressurized water supply of high-rise buildings, garden sprinkler irrigation, fire pressurization, distance transportation, HVAC refrigeration cycle, bathroom and other cold and warm water circulation pressurization and equipment supporting, with the operating temperature less than 80°C.

## Feature

1. Compact structure, small volume, beautiful outlook. The lower barycenter of the vertical structure which coincides with the center of the pump feet strengthens the stability of running and the duration.
2. Easy to mount. Because of the same apertures of both inlet and outlet which also locate on the same central line, the pump can be directly mounted on and part of the pipeline just as a valve. The motor is covered with a rainproof cap so that operation can be done outdoors. Mounting feet are equipped with the pump so that it can be stably mounted.
3. Stable running, low noise, high concentricity of components. Bearings of low noise are used for the motor, the impellers are of best dynamic and static balance, no vibration at running and the environment thus being improved.
4. No leakage. The shaft is mechanically sealed with carbide alloy wearable material, settling the serious leakage of the filling seal of a centrifugal pump, extending the duration and ensuring the operation place clean and tidy.
5. Easy to maintain. Not necessary to remove the pipeline for check-out and maintenance, only to take out the nuts on the pump lid, the motor and the driving components.
6. The pump, according to the operation condition of the worksite, maybe vertically, horizontally etc. multiways mounted and also according to the requirements for the flow ans stroke, mounted in parallel and/or in series to increase the needed low and stroke.

## Working Condition

1. Suction pressure  $\leq 1.0\text{MPa}$ , or pump system maximum working pressure  $\leq 1.6\text{MPa}$ , that is, pump inlet pressure + pump head  $\leq 1.6\text{MPa}$ , pump static pressure test pressure is  $2.5\text{MPa}$ , please indicate the system working pressure when ordering. When the working pressure of the pump system is greater than  $1.6\text{MPa}$ , it should be proposed separately at the time of ordering, so that the flow part and the connection part of the pump are made of cast steel.
2. Ambient temperature  $< 40^\circ\text{C}$ , relative humidity  $< 95\%$ . The volume content of solid particles in the conveying medium does not exceed 0.1% of the unit volume, and the particle size is  $< 0.2\text{mm}$ . Note: If the medium is used with fine particles, please indicate when ordering, so that the manufacturer uses wear-resistant mechanical seals.

## Model Definition

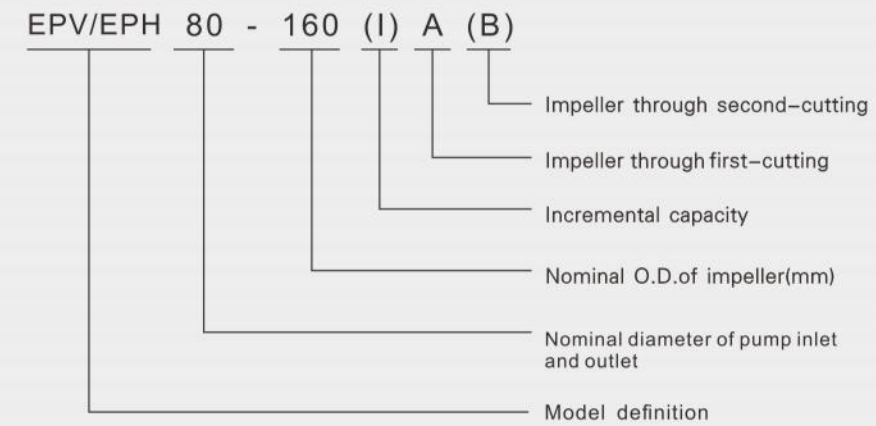

## Technical Parameter

Inlet/Outlet range: DN15~DN300  
 Rated flow: 20~1200m<sup>3</sup>/h  
 Rated head: 3~150m  
 Max working pressure: 20bar

## Liquid Temperature

Type 1: 0°C~80°C  
 Type 2: -20°C~120°C

## Product Structure

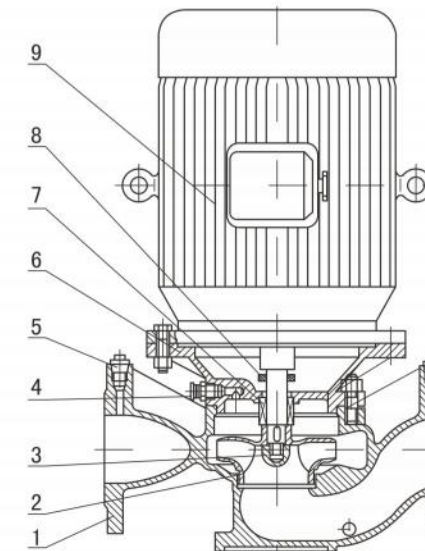

No	Name	Quantity
1	Pump case	1
2	Impeller	1
3	Impeller nut	1
4	Air discharge valve	1
5	Plug	3
6	Pump cover	1
7	Mechanical seal	1
8	Water-blocking ring	1
9	Motor	1

### Performance Curve

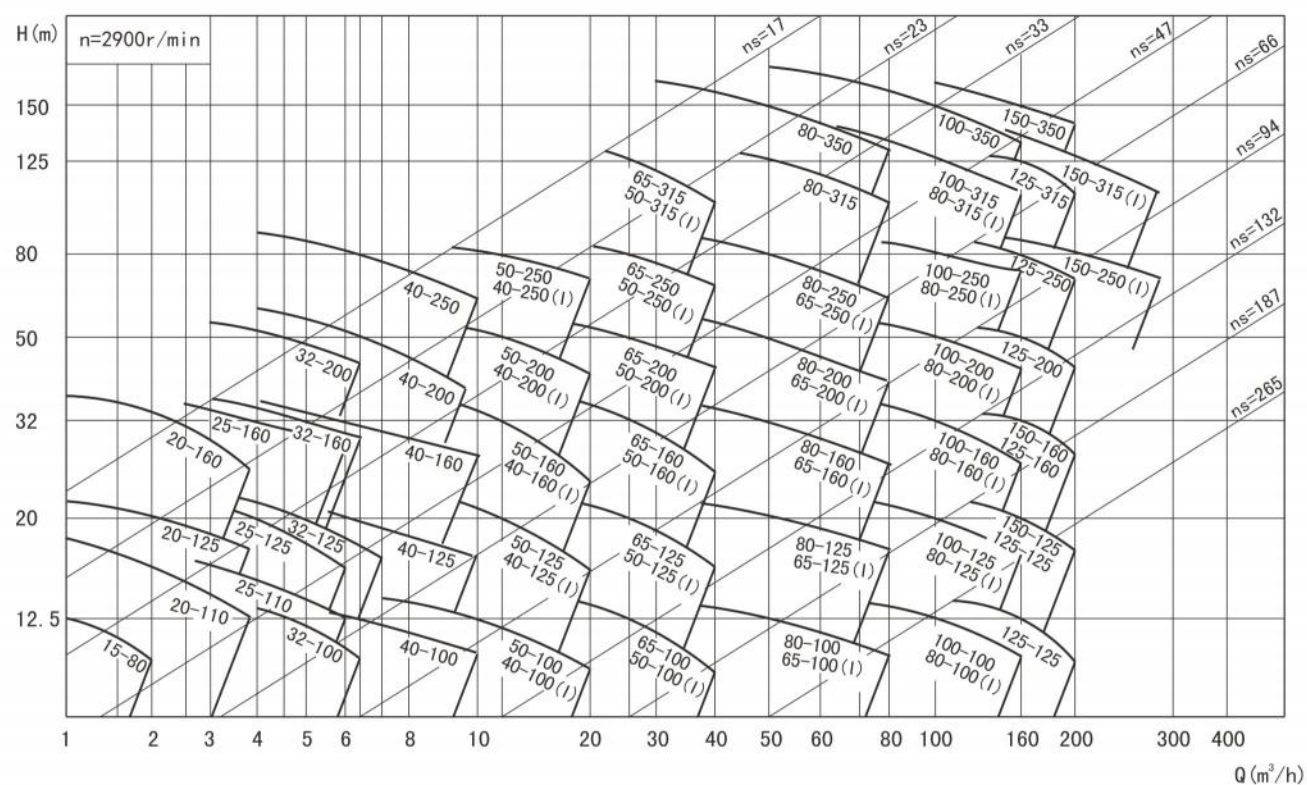

### Flange Dimension

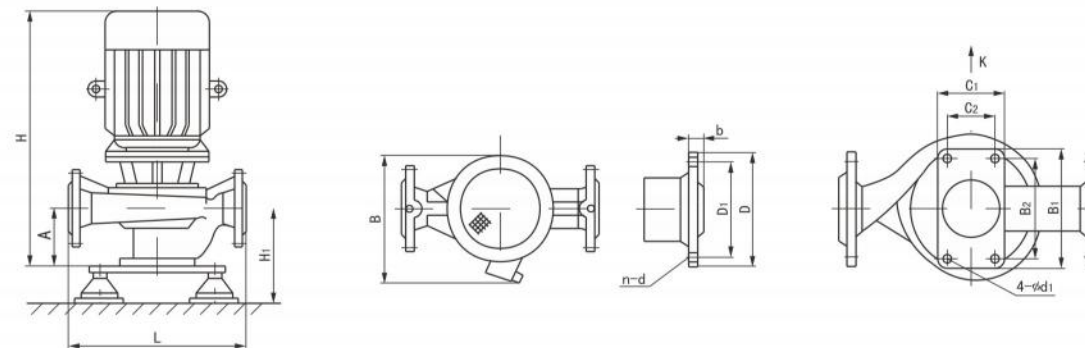

Flange dimension				
DN	D	D1	n-d	b
φ 25	φ115	φ 85	4-φ 14	16
φ 32	φ140	φ 100	4-φ 18	18

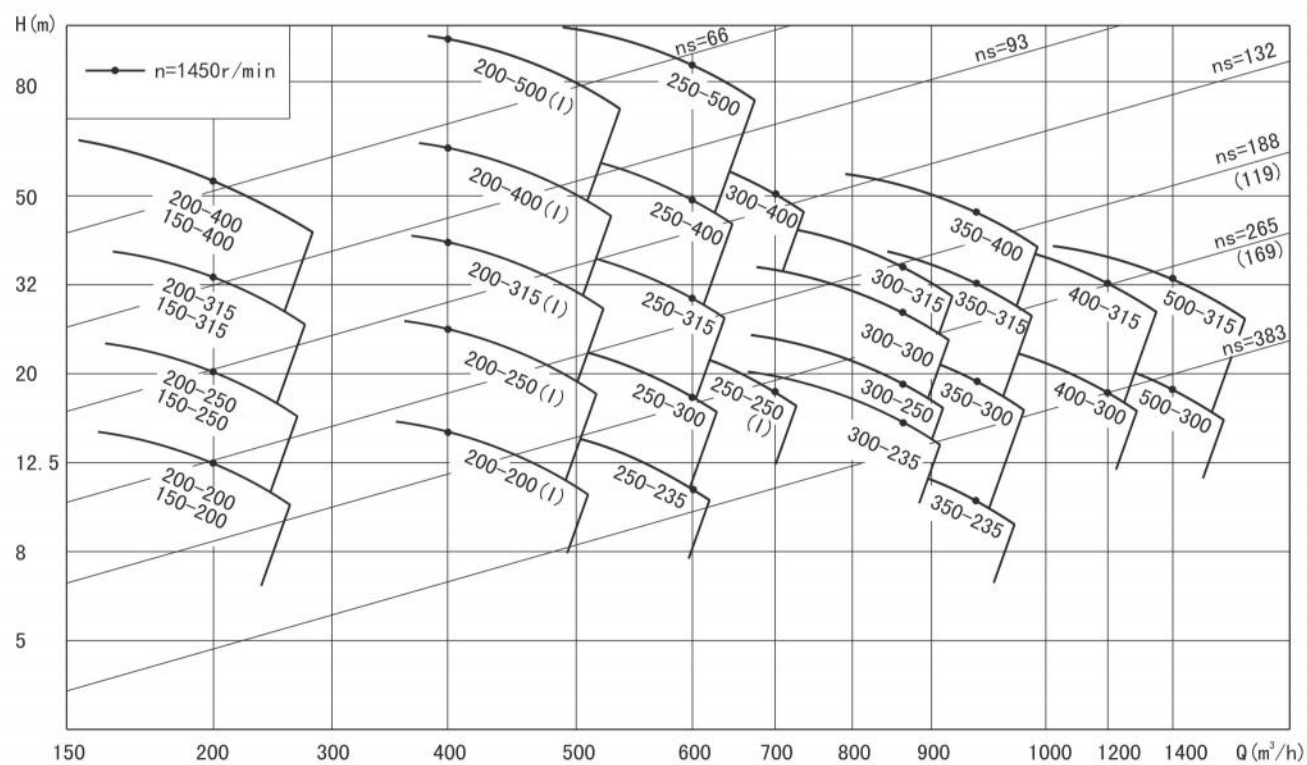

### Performance Table

Model	Rated flow		Rated head	Efficiency	Rotational Speed	Power	Cavitation	Weight
	m³/h	L/s	m	%	r/min	kW	m	kg
15-80	1.1	0.30	8.5	26	2900	0.18	2.5	17
	1.5	0.42	8	34				
	2	0.56	7	34				
20-110	1.8	0.50	16	25	2900	0.37	2.5	25
	2.5	0.69	15	34				
	3.3	0.91	13.5	35				
20-125	1.8	0.50	21	23	2900	0.75	2.5	35
	2.5	0.69	20	28				
	3.3	0.91	18.6	26				
20-160	1.8	0.50	33	19	2900	1.1	2.5	35
	2.5	0.69	32	25				
	3.3	0.91	30	23				
25-110	2.8	0.78	16	34	2900	0.75	2.5	29
	4	1.11	15	42				
	5.2	1.44	13.5	41				
25-125	2.8	0.78	20.5	28	2900	0.75	2.5	33
	4	1.11	20	36				
	5.2	1.44	18	35				
25-125A	2.5	0.69	17	35	2900	0.75	2.5	32
	3.6	1.00	16	35				
	4.6	1.28	14.5	35				
25-160	2.8	0.78	33	24	2900	1.5	2.5	39
	4	1.11	32	32				
	5.2	1.44	30	33				
25-160A	2.6	0.72	29	31	2900	1.1	2.5	35
	3.7	1.03	28	31				
	4.9	1.36	26	31				
32-100	3.5	0.97	14.5	34	2900	0.55	2.5	35
	4.5	1.25	12.5	40				
	5.3	1.47	11	35				
32-125	3.5	0.97	22	40	2900	0.75	2.5	35
	5	1.39	20	44				
	6.5	1.81	18	42				
32-125A	3.1	0.86	17.6	43	2900	0.75	2.5	34
	4.5	1.25	16	43				
	5.8	1.61	14.4	43				
32-160	3.5	0.97	33	24	2900	1.5	2.5	42
	5	1.39	32	32				
	6.5	1.81	30	33				
32-160A	3.5	0.97	26.5	24	2900	1.1	2.5	43
	4.5	1.25	25	32				
	6	1.67	19	33				

## Flange Dimension

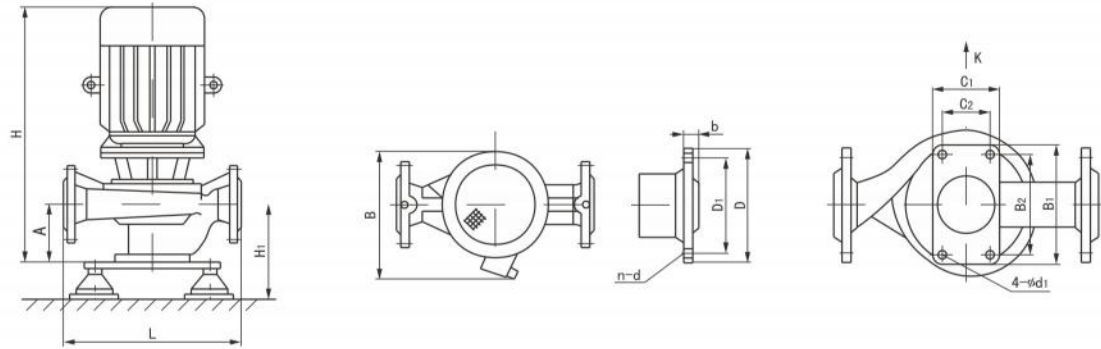

Flange dimension				
DN	D	D1	n-d	b
φ 32	φ 140	φ 100	4-φ 18	18
φ 40	φ 150	φ 110	4-φ 18	18

## Flange Dimension

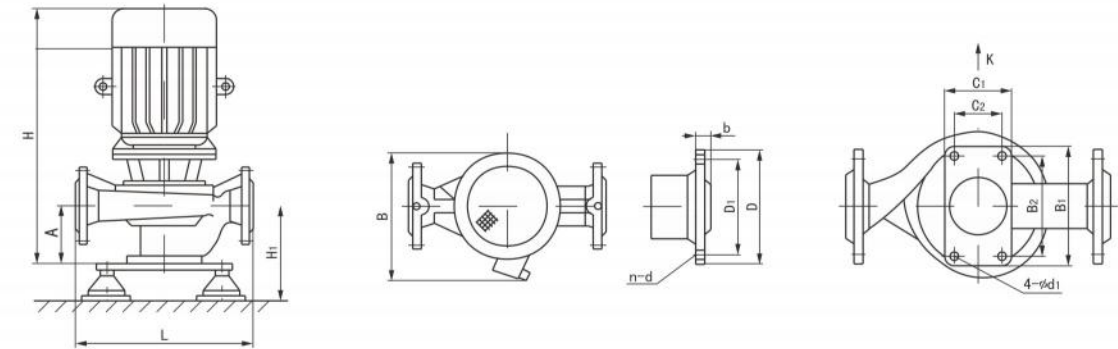

Flange dimension				
DN	D	D1	n-d	b
φ 40	φ 150	φ 110	4-φ 18	18

## Performance Table

Model	Rated flow		Rated head	Efficiency	Rotational Speed	Power	Cavitation	Weight
	m <sup>3</sup> /h	L/s	m	%	r/min	kW	m	kg
32-160(I)	4.4	1.22	33.2	34	2900	2.2	2.5	45
	6.3	1.75	32	40				
	8.3	2.31	30.2	42				
32-200	3.5	0.97	51	26	2900	3	2.5	61
	5	1.39	50	33				
	6.5	1.81	48	32				
32-200A	3.1	0.86	44.6	34	2900	2.2	2.5	53
	4.5	1.25	44	40				
	5.8	1.61	42.7	42				
32-200B	2.45	0.68	40	34	2900	1.5	2.5	40
	3.5	0.97	38	40				
	4.55	1.26	33	42				
32-200(I)	4.4	1.22	50.5	26	2900	4	2.5	70
	6.3	1.75	50	33				
	8.3	2.31	48	35				
40-100	4.4	1.22	13.2	48	2900	0.75	2.5	34
	6.3	1.75	12.5	54				
	8.3	2.31	11.3	53				
40-100A	3.9	1.08	10.6	52	2900	0.75	2.5	33
	5.6	1.56	10	52				
	7.4	2.06	9	52				
40-125	4.4	1.22	21	41	2900	1.1	2.5	38
	6.3	1.75	20	46				
	8.3	2.31	18	43				
40-125A	3.9	1.08	17.6	40	2900	0.75	2.5	36
	5.6	1.56	16	45				
	7.4	2.06	14.4	41				
40-160	4.4	1.22	33	35	2900	2.2	2.5	46
	6.3	1.75	32	40				
	8.3	2.31	30	40				
40-160A	4.1	1.14	29	34	2900	1.5	2.5	42
	5.9	1.64	28	39				
	7.8	2.17	26.3	39				
40-160B	3.8	1.06	25.5	34	2900	1.1	2.5	38
	5.5	1.53	24	38				
	7.2	2.00	22.5	37				
40-200	4.4	1.22	51	26	2900	4	2.5	72
	6.3	1.75	50	33				
	8.3	2.31	48	32				
40-200A	4.1	1.14	45	26	2900	3	2.5	62
	5.9	1.64	44	31				
	7.8	2.17	42	30				

## Performance Table

Model	Rated flow		Rated head	Efficiency	Rotational Speed	Power	Cavitation	Weight
	m <sup>3</sup> /h	L/s	m	%	r/min	kW	m	kg
40-200B	3.7	1.03	38	29	2900	2.2	2.5	53
	5.3	1.47	36	29				
	7	1.94	34.5	29				
40-250	4.4	1.22	82	24	2900	7.5	2.5	105
	6.3	1.75	80	28				
	8.3	2.31	74	28				
40-250A	4.1	1.14	72	24	2900	5.5	2.5	98
	5.9	1.64	70	28				
	7.8	2.17	65	27				
40-250B	3.8	1.06	61.5	23	2900	4	2.5	77
	5.5	1.53	60	27				
	7	1.94	56	26				
40-100(I)	8.8	2.44	13.2	55	2900	1.1	2.5	39
	12.5	3.47	12.5	62				
	16.3	4.53	11.3	60				
40-100(I)A	8	2.22	10.6	60	2900	0.75	2.5	37
	11	3.06	10	60				
	14.5	4.03	9	60				
40-125(I)	8.8	2.44	21.2	49	2900	1.5	2.5	43
	12.5	3.47	20	58				
	16.3	4.53	17.8	57				
40-125(I)A	8	2.22	17	57	2900	1.1	2.5	39
	11	3.06	16	57				
	14.5	4.03	14	57				
40-160(I)	8.8	2.44	33	45	2900	3	2.5	57
	12.5	3.47	32	52				
	16.3	4.53	30	51				
40-160(I)A	8.2	2.28	29	44	2900	2.2	2.5	47
	11.7	3.25	28	51				
	15.2	4.22	26	50				
40-160(I)B	7.3	2.03	23	50	2900	1.5	2.5	43
	10.4	2.89	22	50				
	13.5	3.75	20.5	50				
40-200(I)	8.8	2.44	51.2	38	2900	5.5	2.5	91
	12.5	3.47	50	46				
	16.3	4.53	48	46				
40-200(I)A	8.3	2.31	45	37	2900	4	2.5	72
	11.7	3.25	44	45				
	15.3	4.25	42	45				
40-200(I)B	7.5	2.08	37	44	2900	3	2.5	63
	10.6	2.94	36	44				
	13.8	3.83	34	44				

## Flange Dimension

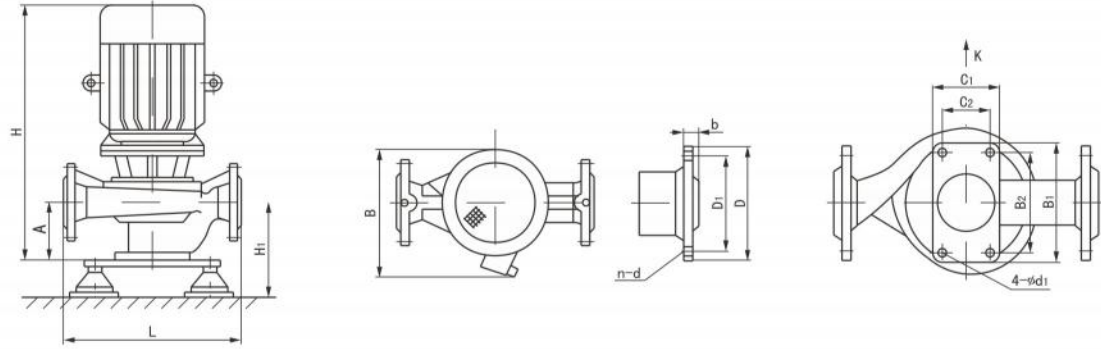

Flange dimension				
DN	D	D1	n-d	b
φ40	φ150	φ110	4- φ18	18
φ50	φ165	φ125	4- φ18	20

## Flange Dimension

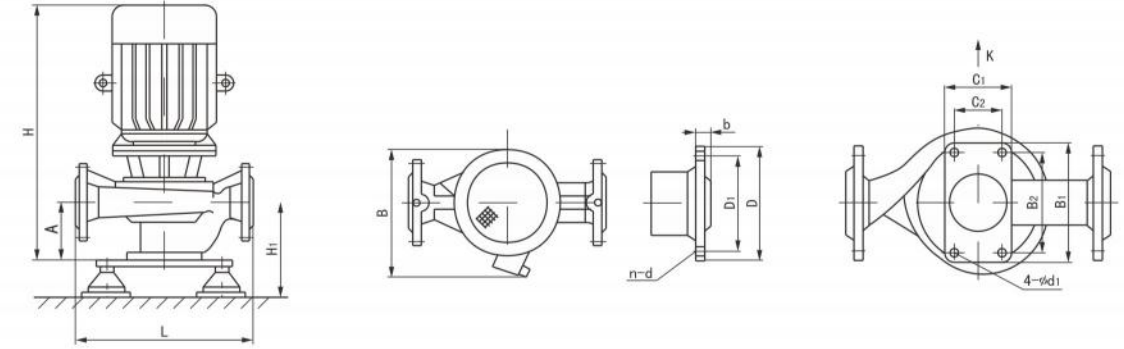

Flange dimension				
DN	D	D1	n-d	b
φ50	φ165	φ125	4- φ18	20

## Performance Table

Model	Rated flow		Rated head	Efficiency	Rotational Speed	Power	Cavitation	Weight
	m <sup>3</sup> /h	L/s	m	%	r/min	kW	m	kg
40-250(I)	8.8	2.44	81.2	31	2900	11	2.5	157
	12.5	3.47	80	38				
	16.3	4.53	77.5	40				
40-250(I)A	8.2	2.28	71	38	2900	7.5	2.5	107
	11.6	3.22	70	38				
	15.2	4.22	68	38				
40-250(I)B	7.6	2.11	61.4	37	2900	5.5	2.5	100
	10.8	3.00	60	37				
	14	3.89	58	37				
40-250(I)C	7.1	1.97	53.2	36	2900	5.5	2.5	99
	10	2.78	52	36				
	13.1	3.64	50.4	36				
50-100	8.8	2.44	13.6	55	2900	1.1	2.5	38
	12.5	3.47	12.5	62				
	16.3	4.53	11.3	60				
50-100A	8	2.22	11	60	2900	0.75	2.5	36
	11	3.06	10	60				
	14.5	4.03	9	60				
50-125	8.8	2.44	21.5	49	2900	1.5	2.5	43
	12.5	3.47	20	58				
	16.3	4.53	17.8	57				
50-125A	8	2.22	17	57	2900	1.1	2.5	39
	11	3.06	16	57				
	14.5	4.03	14	57				
50-160	8.8	2.44	33	45	2900	3	2.5	59
	12.5	3.47	32	52				
	16.3	4.53	30	51				
50-160A	8.2	2.28	29	44	2900	2.2	2.5	48
	11.7	3.25	28	51				
	15.2	4.22	26	50				
50-160B	7.3	2.03	23	50	2900	1.5	2.5	44
	10.4	2.89	22	50				
	13.5	3.75	20.5	50				
50-200	8.8	2.44	52	38	2900	5.5	2.5	92
	12.5	3.47	50	46				
	16.3	4.53	48	46				
50-200A	8.3	2.31	45.8	37	2900	4	2.5	73
	11.7	3.25	44	45				
	15.3	4.25	42	45				
50-200B	7.5	2.08	37	44	2900	3	2.5	63
	10.6	2.94	36	44				
	13.8	3.83	34	44				

## Performance Table

Model	Rated flow		Rated head	Efficiency	Rotational Speed	Power	Cavitation	Weight
	m <sup>3</sup> /h	L/s	m	%	r/min	kW	m	kg
50-250	8.8	2.44	82	29	2900	11	2.5	162
	12.5	3.47	80	38				
	16.3	4.53	77.5	40				
50-250A	8.2	2.28	71.5	38	2900	7.5	2.5	112
	11.6	3.22	70	38				
	15.2	4.22	68	38				
50-250B	7.6	2.11	61.4	37	2900	7.5	2.5	105
	10.8	3.00	60	37				
	14	3.89	58	37				
50-250C	7.1	1.97	53.2	36	2900	5.5	2.5	104
	10	2.78	52	36				
	13.1	3.64	50.4	36				
50-100(I)	17.5	4.86	13.7	67	2900	1.5	2.5	44
	25	6.94	12.5	69				
	32.5	9.03	10.5	69				
50-100(I)A	15.6	4.33	11	65	2900	1.1	2.5	40
	22.3	6.19	10	67				
	29	8.06	8.4	68				
50-125(I)	17.5	4.86	21.5	60	2900	3	2.5	59
	25	6.94	20	68				
	32.5	9.03	18	67				
50-125(I)A	15.6	4.33	17	58	2900	2.2	2.5	50
	22.3	6.19	16	66				
	29	8.06	13.6	65				
50-160(I)	17.5	4.86	34.4	54	2900	4	2.5	72
	25	6.94	32	63				
	32.5	9.03	27.5	60				
50-160(I)A	16.4	4.56	30	54	2900	3	2.5	62
	23.4	6.50	28	62				
	30.4	8.44	24	59				
50-160(I)B	15	4.17	26	58	2900	2.2	2.5	52
	21.6	6.00	24	58				
	28	7.78	20.6	58				
50-200(I)	17.5	4.86	52.7	49	2900	7.5	2.5	102
	25	6.94	50	58				
	32.5	9.03	45.5	59				
50-200(I)A	16.4	4.56	46.4	48	2900	5.5	2.5	96
	23.5	6.53	44	57				
	30.5	8.47	40	58				
50-200(I)B	15.2	4.22	40	55	2900	4	2.5	77
	21.8	6.06	38	55				
	28.3	7.86	34.5	55				

## Flange Dimension

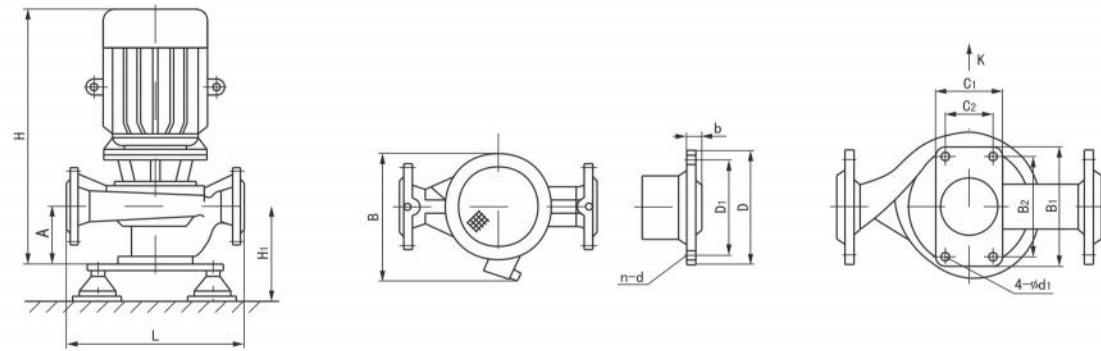

Flange dimension				
DN	D	D1	n-d	b
φ 50	φ 165	φ 125	4-φ 18	20
φ 65	φ 185	φ 145	4-φ 18	20

## Flange Dimension

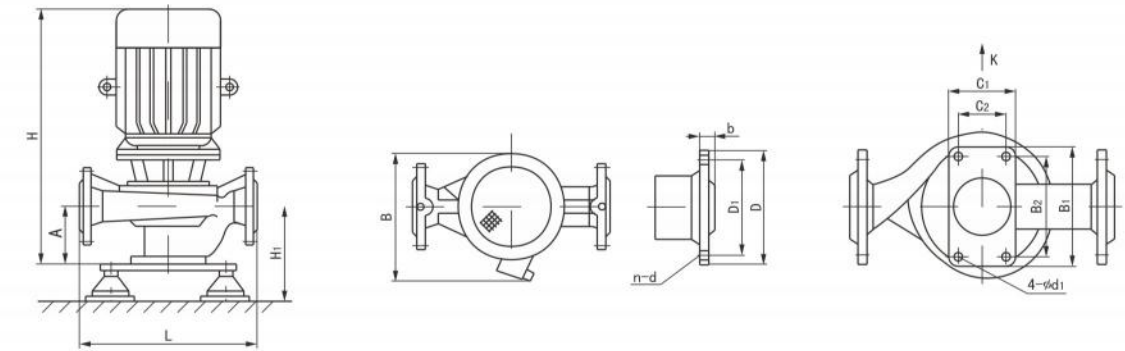

Flange dimension				
DN	D	D1	n-d	b
φ 65	φ 185	φ 145	4-φ 18	20

## Performance Table

Model	Rated flow		Rated head	Efficiency	Rotational Speed	Power	Cavitation	Weight
	m <sup>3</sup> /h	L/s	m	%	r/min	kW	m	kg
50-250(I)	17.5	4.86	82	39	2900	15	2.5	176
	25	6.94	80	50				
	32.5	9.03	76.5	52				
50-250(I)A	16.4	4.56	71.5	39	2900	11	2.5	166
	23.4	6.50	70	50				
	30.5	8.47	67	52				
50-250(I)B	15	4.17	61	38	2900	7.5	2.5	118
	21.6	6.00	60	49				
	28	7.78	57.4	54				
50-315(I)	17.5	4.86	128	30	2900	30	2.5	340
	25	6.94	125	40				
	32.5	9.03	122	44				
50-315(I)A	16.6	4.61	115	30	2900	22	2.5	254
	23.7	6.58	113	40				
	31	8.61	110	44				
50-315(I)B	15.7	4.36	103	39	2900	18.5	2.5	234
	22.5	6.25	101	39				
	29.2	8.11	98	39				
50-315(I)C	14.4	4.00	86	38	2900	15	2.5	210
	20.6	5.72	85	38				
	26.8	7.44	83	38				
65-100	17.5	4.86	13.7	67	2900	1.5	3	46
	25	6.94	12.5	69				
	32.5	9.03	10.5	69				
65-100A	15.6	4.33	11	65	2900	1.1	3	41
	22.3	6.19	10	67				
	29	8.06	8.4	68				
65-125	17.5	4.86	21.5	60	2900	3	3	61
	25	6.94	20	68				
	32.5	9.03	18	67				
65-125A	15.6	4.33	17	58	2900	2.2	3	52
	22.3	6.19	16	66				
	29	8.06	14.4	65				
65-160	17.5	4.86	34.4	54	2900	4	3	73
	25	6.94	32	63				
	32.5	9.03	27.5	60				
65-160A	16.4	4.56	30	54	2900	3	3	63
	23.4	6.50	28	63				
	30.4	8.44	24	59				
65-160B	15	4.17	26	58	2900	2.2	3	53
	21.6	6.00	24	58				
	28	7.78	20.6	58				

## Performance Table

Model	Rated flow		Rated head	Efficiency	Rotational Speed	Power	Cavitation	Weight
	m <sup>3</sup> /h	L/s	m	%	r/min	kW	m	kg
65-200	17.5	4.86	52.7	49	2900	7.5	3	105
	25	6.94	50	58				
	32.5	9.03	45.5	59				
65-200A	16.4	4.56	46.4	48	2900	5.5	3	99
	23.5	6.53	44	57				
	30.5	8.47	40	58				
65-200B	15.2	4.22	40	48	2900	4	3	80
	21.8	6.06	38	55				
	28.3	7.86	34.5	58				
65-250	17.5	4.86	82	39	2900	15	3	177
	25	6.94	80	50				
	32.5	9.03	76.5	52				
65-250A	16.4	4.56	71.5	39	2900	11	3	167
	23.4	6.50	70	50				
	30.5	8.47	67	52				
65-250B	15	4.17	61	38	2900	7.5	3	119
	21.6	6.00	60	49				
	28	7.78	57.4	54				
65-315	17.5	4.86	127	32	2900	30	3	341
	25	6.94	125	40				
	32.5	9.03	122	44				
65-315A	16.6	4.61	115	32	2900	22	3	255
	23.7	6.58	113	40				
	31	8.61	110	44				
65-315B	15.7	4.36	103	39	2900	18.5	3	234
	22.5	6.25	101	39				
	29.2	8.11	98	39				
65-315C	14.4	4.00	86	38	2900	15	3	210
	20.6	5.72	85	38				
	26.8	7.44	83	38				
65-100(I)	35	9.72	13.8	67	2900	3	3	65
	50	13.89	12.5	73				
	65	18.06	10	70				
65-100(I)A	31.3	8.69	11	66	2900	2.2	3	55
	44.7	12.42	10	72				
	58	16.11	8	69				
65-125(I)	35	9.72	22	67	2900	5.5	3	99
	50	13.89	20	72.5				
	65	18.06	17	70				
65-125(I)A	31.3	8.69	17.5	66	2900	4	3	78
	45	12.50	16	71				
	58	16.11	13.6	69				

## Flange Dimension

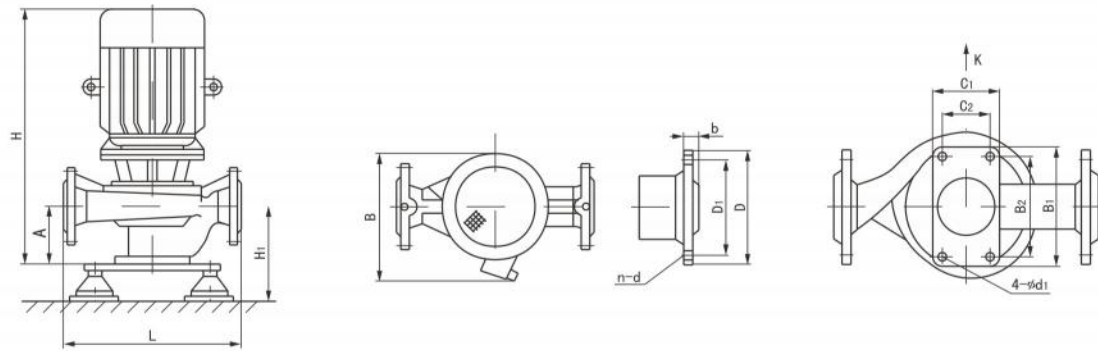

Flange dimension				
DN	D	D1	n-d	b
φ80	φ200	φ160	8-φ18	22

## Flange Dimension

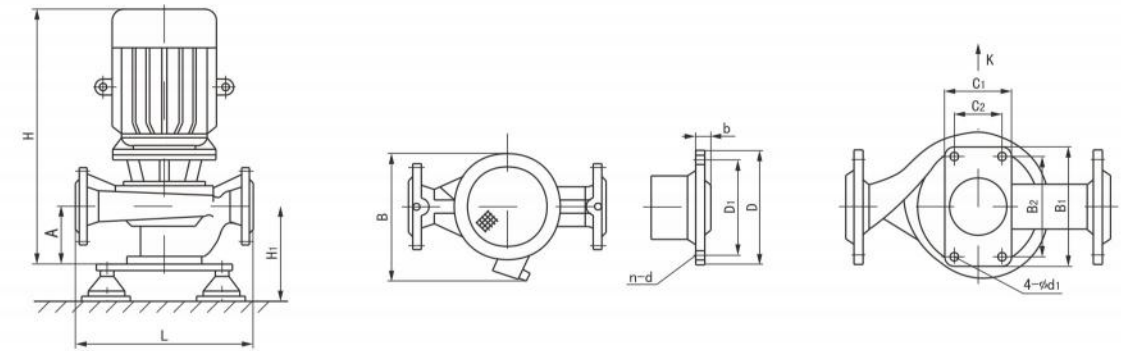

Flange dimension				
DN	D	D1	n-d	b
φ80	φ200	φ160	8-φ18	22
φ100	φ220	φ180	8-φ18	24

## Performance Table

Model	Rated flow		Rated head	Efficiency	Rotational Speed	Power	Cavitation	Weight
	m <sup>3</sup> /h	L/s	m	%	r/min	kW	m	kg
80-315B	31	8.6	102.5	53	2900	30	4	343
	44.5	12.4	100	53				
	58	16.1	98	53				
80-315C	29	8.1	88	51	2900	22	4	268
	41	11.4	85	51				
	53.6	14.9	83	51				
80-350	35	9.7	156	44	2900	55	4	530
	50	13.9	150	51				
	65	18.1	139	48				
80-350A	31	8.6	148	43	2900	45	4	420
	44	12.2	142	50				
	57	15.8	134	49				
80-350B	28	7.8	142	42	2900	37	4	360
	40	11.1	135	49				
	52	14.4	127	48				
80-350(I)	50.4	14.0	155	45	2900	75	4	700
	72	20.0	150	52				
	93.6	26.0	143	49				
80-350(I)A	44.8	12.4	147	44	2900	55	4	650
	64	17.8	142	51				
	83.2	23.1	133	48				
80-350(I)B	39.2	10.9	140	43	2900	55	4	650
	56	15.6	135	50				
	72.8	20.2	128	47				
80-100(I)	70	19.4	13.6	66	2900	5.5	4	108
	100	27.8	12.5	76				
	130	36.1	11	75				
80-100(I)A	62.6	17.4	11	64	2900	4	4	86
	89	24.7	10	74				
	116	32.2	8.8	74				
80-125(I)	70	19.4	23.5	70	2900	11	4	160
	100	27.8	20	76				
	130	36.1	14	72				
80-125(I)A	62.6	17.4	19	68	2900	7.5	4	113
	89	24.7	16	74				
	116	32.2	11	63				
80-160(I)	70	19.4	36.5	70	2900	15	4	175
	100	27.8	32	76				
	130	36.1	24	65				
80-160(I)A	65.4	18.2	32	68	2900	11	4	165
	93.5	26.0	28	74				
	121.6	33.8	21	67				

## Performance Table

Model	Rated flow		Rated head	Efficiency	Rotational Speed	Power	Cavitation	Weight
	m <sup>3</sup> /h	L/s	m	%	r/min	kW	m	kg
80-160(I)B	60.6	16.8	26	72	2900	7.5	4	118
	86.6	24.1	24	72				
	112.5	31.3	18	72				
80-200(I)	70	19.4	54	65	2900	22	4	233
	100	27.8	50	74				
	130	36.1	42	73				
80-200(I)A	65.4	18.2	47.5	64	2900	18.5	4	204
	93.5	26.0	44	73				
	121.6	33.8	37	72				
80-200(I)B	61	16.9	41	71	2900	15	4	181
	87	24.2	38	71				
	113	31.4	32	71				
80-250(I)	70	19.4	87	62	2900	37	4	339
	100	27.8	80	69				
	130	36.1	68	68				
80-250(I)A	65.4	18.2	76	61	2900	30	4	333
	93.5	26.0	70	68				
	121.6	33.8	59.5	67				
80-250(I)B	61	16.9	65	66	2900	30	4	333
	87	24.2	60	66				
	113	31.4	51	66				
80-315(I)	70	19.4	132	55	2900	75	4	675
	100	27.8	125	66				
	130	36.1	114	67				
80-315(I)A	66.5	18.5	119	55	2900	55	4	535
	95	26.4	113	66				
	123.6	34.3	103	67				
80-315(I)B	63	17.5	106.6	65	2900	45	4	432
	90	25.0	101	65				
	117	32.5	92	65				
80-315(I)C	58	16.1	90	63	2900	37	4	377
	82	22.8	85	63				
	107	29.7	76	63				
100-100	70	19.4	13.6	66	2900	5.5	4.5	113
	100	27.8	12.5	76				
	130	36.1	11	75				
100-100A	62.6	17.4	11	64	2900	4	4.5	91
	89	24.7	10	74				
	116	32.2	8.8	74				
100-125	70	19.4	23.5	70	2900	11	4.5	161
	100	27.8	20	76				
	130	36.1	14	65				

### Flange Dimension

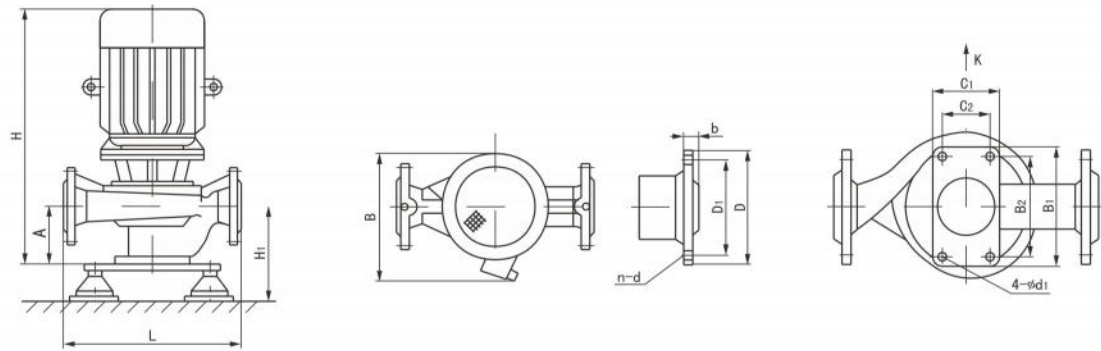

Flange dimension				
DN	D	D1	n-d	b
φ 65	φ 185	φ 145	4-φ 18	20
φ 80	φ 200	φ 160	8-φ 18	22

### Flange Dimension

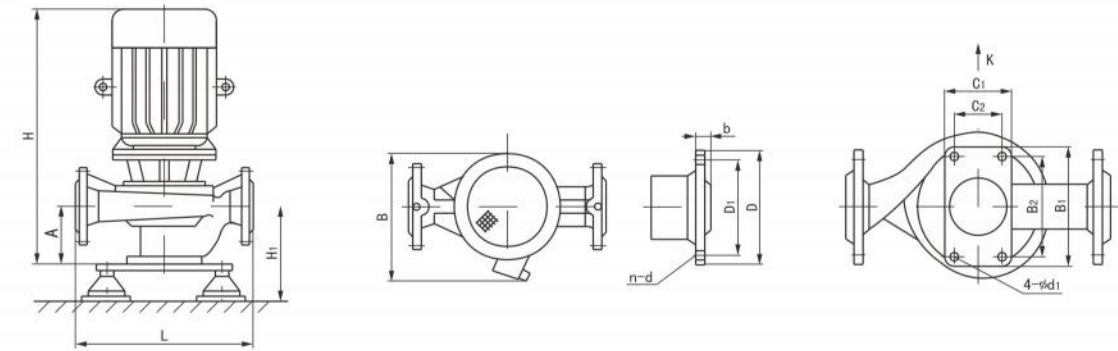

Flange dimension				
DN	D	D1	n-d	b
φ 80	φ 200	φ 160	8-φ 18	22

### Performance Table

Model	Rated flow		Rated head	Efficiency	Rotational Speed	Power	Cavitation	Weight
	m <sup>3</sup> /h	L/s	m	%	r/min	kW	m	kg
65-160(I)	35	9.72	35	63	2900	7.5	3	103
	50	13.89	32	71				
	65	18.06	28	70				
65-160(I)A	32.7	9.08	30.6	62	2900	5.5	3	97
	46.7	12.97	28	70				
	61	16.94	24	69				
65-160(I)B	30.3	8.42	26	69	2900	4	3	77
	43.3	12.03	24	69				
	56.3	15.64	21	69				
65-200(I)	35	9.72	53.5	55	2900	15	3	169
	50	13.89	50	67				
	65	18.06	46	68				
65-200(I)A	32.8	9.11	47	54	2900	11	3	159
	47	13.06	44	66				
	61	16.94	40	67				
65-200(I)B	30.5	8.47	40.6	65	2900	7.5	3	110
	43.5	12.08	38	65				
	56.6	15.72	33.4	65				
65-250(I)	35	9.72	83	52	2900	22	3	232
	50	13.89	80	59				
	65	18.06	72	60				
65-250(I)A	32.5	9.03	73	52	2900	18.5	3	202
	46.7	12.97	70	59				
	61	16.94	63	60				
65-250(I)B	30	8.33	62	58	2900	15	3	178
	43.3	12.03	60	58				
	56	15.56	54	58				
65-315(I)	35	9.72	128	44	2900	37	3	350
	50	13.89	125	54				
	65	18.06	121	57				
65-315(I)A	32.5	9.03	112.6	43	2900	30	3	343
	46.5	12.92	110	54				
	60.5	16.81	106.4	57				
65-315(I)B	31	8.61	102.5	53	2900	30	3	343
	44.5	12.36	100	53				
	58	16.11	98	53				
65-315(I)C	29	8.06	87	51	2900	22	3	260
	41	11.39	85	51				
	53.6	14.89	83	51				
80-100	35	9.72	13.8	67	2900	3	4	67
	50	13.89	12.5	73				
	65	18.06	10	70				

### Performance Table

Model	Rated flow		Rated head	Efficiency	Rotational Speed	Power	Cavitation	Weight
	m <sup>3</sup> /h	L/s	m	%	r/min	kW	m	kg
80-100A	31.3	8.69	11	66	2900	2.2	4	57
	44.7	12.42	10	72				
	58	16.11	8	69				
80-125	35	9.72	22	67	2900	5.5	4	99
	50	13.89	20	72.5				
	65	18.06	17	70				
80-125A	31.3	8.69	17.5	66	2900	4	4	78
	45	12.50	16	71				
	58	16.11	13.6	69				
80-160	35	9.72	35	63	2900	7.5	4	106
	50	13.89	32	71				
	65	18.06	28	70				
80-160A	32.7	9.08	30.6	62	2900	5.5	4	100
	46.7	12.97	28	70				
	61	16.94	24	69				
80-160B	30.3	8.42	26	69	2900	4	4	80
	43.3	12.03	24	69				
	56.3	15.64	21	69				
80-200	35	9.72	53.5	55	2900	15	4	170
	50	13.89	50	67				
	65	18.06	46	68				
80-200A	32.8	9.11	47	55	2900	11	4	160
	47	13.06	44	66				
	61	16.94	40	67				
80-200B	30.5	8.5	40.6	65	2900	7.5	4	111
	43.5	12.1	38	65				
	56.6	15.7	33.4	65				
80-250	35	9.7	83	52	2900	22	4	236
	50	13.9	80	59				
	65	18.1	72	60				
80-250A	32.5	9.0	73	52	2900	18.5	4	206
	46.7	13.0	70	59				
	61	16.9	63	60				
80-250B	30	8.3	62	58	2900	15	4	182
	43.3	12.0	60	58				
	56	15.6	54	58				
80-315	35	9.7	128	43	2900	37	4	358
	50	13.9	125	54				
	65	18.1	122	57				
80-315A	32.5	9.0	112.6	43	2900	30	4	351
	46.6	12.9	110	54				
	60.5	16.8	107.4	57				

## Flange Dimension

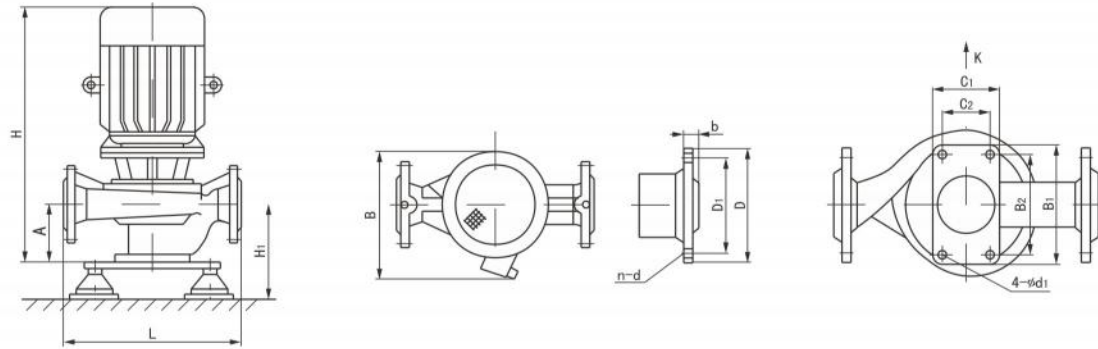

Flange dimension				
DN	D	D1	n-d	b
φ100	φ220	φ180	8-φ18	24

## Flange Dimension

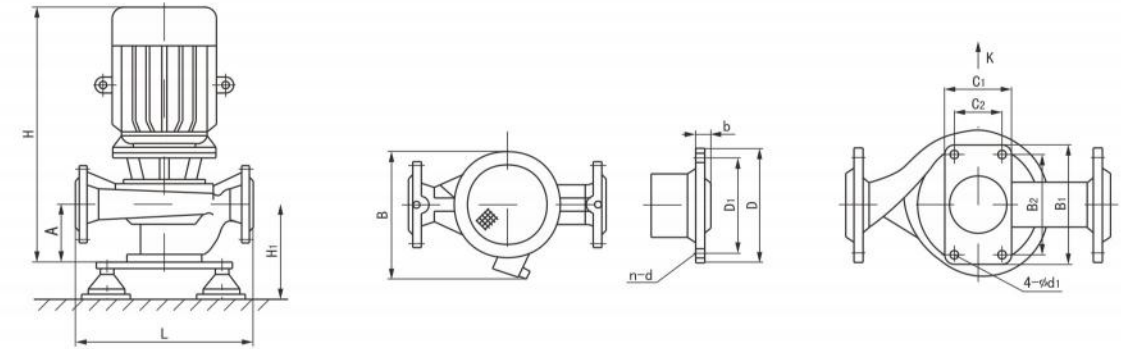

Flange dimension				
DN	D	D1	n-d	b
φ100	φ220	φ180	8-φ18	24

## Performance Table

Model	Rated flow		Rated head	Efficiency	Rotational Speed	Power	Cavitation	Weight
	m <sup>3</sup> /h	L/s	m	%	r/min	kW	m	kg
100-125A	62.6	17.4	19	68	2900	7.5	4.5	114
	89	24.7	16	74				
	116	32.2	11	63				
100-160	70	19.4	36.5	70	2900	15	4.5	177
	100	27.8	32	76				
	130	36.1	24	65				
100-160A	65.4	18.2	32	68	2900	11	4.5	167
	93.5	26.0	28	74				
	121.6	33.8	21	67				
100-160B	60.6	16.8	27	72	2900	7.5	4.5	120
	86.6	24.1	24	72				
	112.5	31.3	18	72				
100-200	70	19.4	54	65	2900	22	4.5	232
	100	27.8	50	74				
	130	36.1	42	73				
100-200A	65.4	18.2	47.5	64	2900	18.5	4.5	203
	93.5	26.0	44	73				
	121.6	33.8	37	72				
100-200B	61	16.9	41	71	2900	15	4.5	180
	87	24.2	38	71				
	113	31.4	32	71				
100-250	70	19.4	87	62	2900	37	4.5	335
	100	27.8	80	69				
	130	36.1	68	68				
100-250A	65.4	18.2	76	61	2900	30	4.5	328
	93.5	26.0	70	68				
	121.6	33.8	59.5	67				
100-250B	61	16.9	65	66	2900	30	4.5	328
	87	24.2	60	66				
	113	31.4	51	66				
100-315	70	19.4	132	55	2900	75	4.5	675
	100	27.8	125	66				
	130	36.1	114	67				
100-315A	66.5	18.5	119	55	2900	55	4.5	535
	95	26.4	113	66				
	123.6	34.3	103	67				
100-315B	63	17.5	106.6	65	2900	45	4.5	432
	90	25.0	101	65				
	117	32.5	92	65				
100-315C	58	16.1	90	63	2900	37	4.5	377
	82	22.8	85	63				
	107	29.7	76	63				

## Performance Table

Model	Rated flow		Rated head	Efficiency	Rotational Speed	Power	Cavitation	Weight
	m <sup>3</sup> /h	L/s	m	%	r/min	kW	m	kg
100-350	70	19.4	156	63	2900	90	4.5	740
	100	27.8	150	67				
	130	36.1	148	65				
100-350A	64	17.8	148	63	2900	75	4.5	650
	88	24.4	142	67				
	114.4	31.8	133	65				
100-350B	56	15.6	140	63	2900	75	4.5	510
	80	22.2	135	67				
	104	28.9	125	65				
100-350(I)	88.2	24.5	157	64	2900	110	4.5	830
	126	35.0	150	68				
	163.8	45.5	141	66				
100-350(I)A	81.2	22.6	149	63	2900	90	4.5	760
	116	32.2	142	67				
	150.8	41.9	132	65				
100-350(I)B	75.6	21.0	142	62	2900	75	4.5	680
	108	30.0	135	66				
	140.4	39.0	126	64				
100-100(I)	96	26.7	14	64	2900	11	4.5	173
	160	44.4	12.5	73				
	192	53.3	10	70				
100-125(I)	96	26.7	24	62	2900	15	4.5	182
	160	44.4	20	74				
	192	53.3	14	69				
100-125(I)A	84	23.3	20	64	2900	11	4.5	173
	140	38.9	17	72				
	168	46.7	12	68				
100-160(I)	96	26.7	36	69	2900	22	4.5	241
	160	44.4	32	79				
	192	53.3	28	75				
100-160(I)A	84	23.3	32	66	2900	18.5	4.5	210
	140	38.9	28	76				
	168	46.7	23.5	72				
100-200(I)	96	26.7	53	69	2900	37	4.5	334
	160	44.4	50	79				
	192	53.3	45	78				
100-200(I)A	84	23.3	48	64	2900	30	4.5	328
	140	38.9	45	74				
	168	46.7	40	73				
100-200(I)B	60	16.7	43	72	2900	22	4.5	243
	100	27.8	40	72				
	120	33.3	36	72				

## Flange Dimension

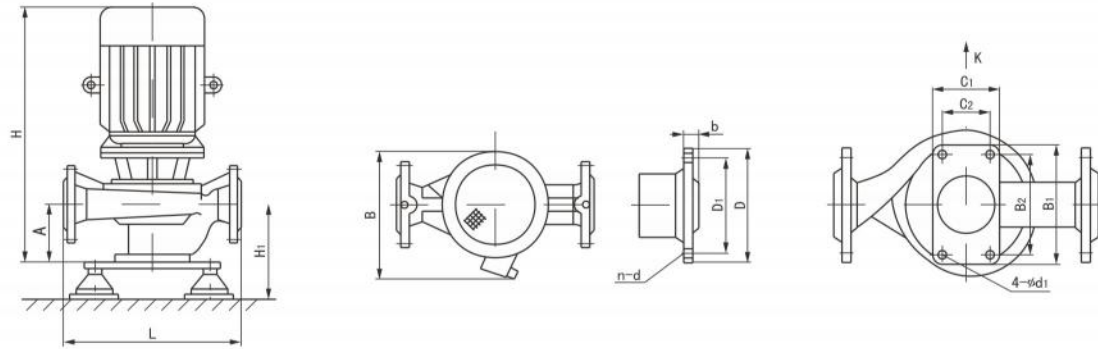

Flange dimension				
DN	D	D1	n-d	b
φ100	φ220	φ180	8-φ18	24
φ125	φ250	φ210	8-φ18	26

## Flange Dimension

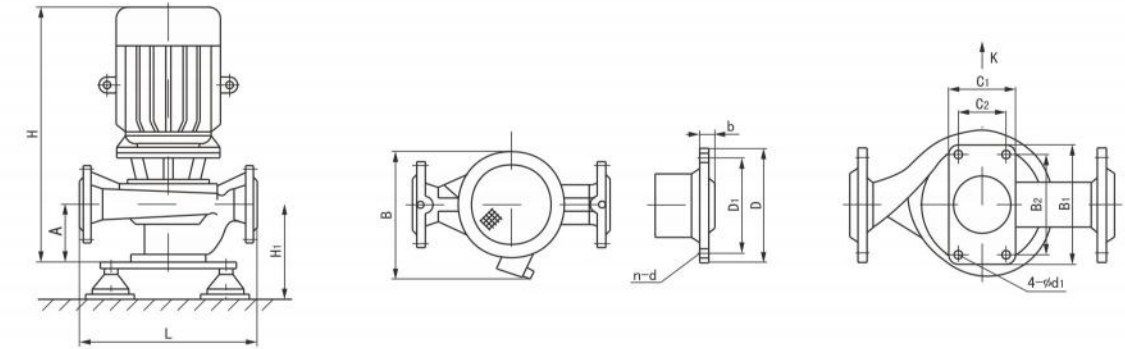

Flange dimension				
DN	D	D1	n-d	b
φ125	φ250	φ210	8-φ18	26
φ150	φ285	φ240	8-φ22	26

## Performance Table

Model	Rated flow		Rated head	Efficiency	Rotational Speed	Power	Cavitation	Weight
	m <sup>3</sup> /h	L/s	m	%	r/min	kW	m	kg
100-250(I)	96	26.7	83	65	2900	55	4.5	525
	160	44.4	80	77				
	192	53.3	72	74				
100-250(I)A	84	23.3	75	60	2900	45	4.5	415
	140	38.9	72	72				
	168	46.7	65	69				
100-250(I)B	60	16.7	68	70	2900	37	4.5	359
	100	27.8	65	70				
	120	33.3	58	70				
100-315(I)	96	26.7	133	72	2900	90	4.5	760
	160	44.7	125	70				
	192	53.3	119	74				
100-315(I)A	90	25.0	117	75	2900	75	4.5	684
	150	41.7	110	75				
	180	50.0	104.6	75				
100-315(I)B	86	23.9	106.4	75	2900	55	4.5	684
	143	39.7	100	75				
	172	47.8	95.2	75				
100-315(I)C	80.5	22.4	96	69	2900	55	5	570
	134	37.2	88	69				
	161	44.7	86	69				
125-100	96	26.7	13	82	2900	11	5	183
	160	44.4	12.5	82				
	192	53.3	12	82				
125-100A	86	23.9	10.4	77	2900	7.5	5	139
	143	39.7	10	77				
	172	47.8	9.6	77				
125-125	96	26.7	22.6	80	2900	15	5	192
	160	44.4	20	80				
	192	53.3	17	80				
125-125A	86	23.9	18	77	2900	11	5	182
	143	39.7	16	77				
	172	47.8	13.6	77				
125-160	96	26.7	36	78	2900	22	5	245
	160	44.4	32	78				
	192	53.3	28	78				
125-160A	90	25.0	31.5	76	2900	18.5	5	216
	150	41.7	28	76				
	180	50.0	24.5	76				
125-160B	83	23.1	27	73	2900	15	5	193
	138	38.3	24	73				
	166	46.1	21	73				

## Performance Table

Model	Rated flow		Rated head	Efficiency	Rotational Speed	Power	Cavitation	Weight
	m <sup>3</sup> /h	L/s	m	%	r/min	kW	m	kg
125-200	96	26.7	55	77	2900	37	5	345
	160	44.4	50	77				
	192	53.3	46	77				
125-200A	90	25.0	48.4	76	2900	30	5	338
	150	41.7	44	76				
	180	50.0	40.5	76				
125-200B	83	23.1	41.3	75	2900	22	5	254
	138	38.3	37.5	75				
	166	46.1	34.5	75				
125-250	96	26.7	87	75	2900	55	5	538
	160	44.4	80	75				
	192	53.3	73	75				
125-250A	90	25.0	76	74	2900	45	5	428
	150	41.7	70	74				
	180	50.0	64	74				
125-250B	83	23.1	65	73	2900	37	5	372
	138	38.3	60	73				
	166	46.1	55	73				
125-315	96	26.7	133	70	2900	90	5	790
	160	44.4	125	70				
	192	53.3	119	70				
125-315A	90	25.0	117	70	2900	75	5	714
	150	41.7	110	70				
	180	50.0	104.6	70				
125-315B	86	23.9	106.4	69	2900	75	5	710
	143	39.7	100	69				
	172	47.8	95.2	69				
125-315C	80.5	22.4	96	67	2900	55	5	570
	134	37.2	88	67				
	161	44.7	86	67				
125-350	115	31.9	160	64	2900	110	5	970
	160	44.4	150	71				
	208	57.8	139	67				
125-350A	105	29.2	152	63	2900	110	5	720
	150	41.7	142	70				
	195	54.2	131	66				
125-350B	98	27.2	110	62	2900	90	5	690
	140	38.9	101	69				
	182	50.6	90	65				
125-350(I)	126	35.0	160	66	2900	132	5	1130
	180	50.0	150	72				
	234	65.0	138	68				

## Flange Dimension

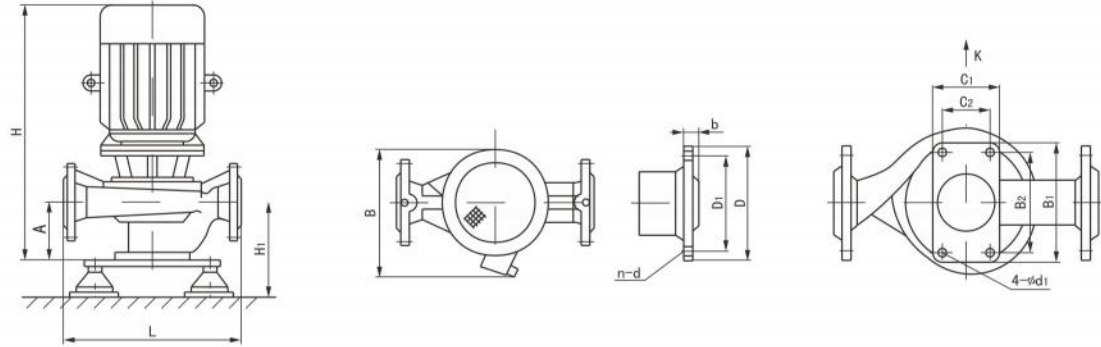

Flange dimension				
DN	D	D1	n-d	b
φ 125	φ 250	φ 210	8-φ 18	26
φ 150	φ 285	φ 240	8-φ 22	26

## Performance Table

Model	Rated flow		Rated head	Efficiency	Rotational Speed	Power	Cavitation	Weight
	m <sup>3</sup> /h	L/s	m	%	r/min	kW	m	kg
125-350(I)A	119	33.1	153	65	2900	110	5	975
	170	47.2	142	71				
	221	61.4	130	67				
125-350(I)B	113.4	31.5	146	64	2900	110	5	970
	162	45.0	135	70				
	210.6	58.5	123	66				
150-125	96	26.7	22.6	66	2900	15	5	203
	160	44.4	20	76				
	192	53.3	17	76				
150-125A	90	25.0	18	77	2900	11	5	193
	150	41.7	16	77				
	180	50.0	13.6	77				
150-160	96	26.7	36	75	2900	22	5	261
	160	44.4	32	75				
	192	53.3	27	75				
150-160A	90	25.0	32	76	2900	18.5	5	232
	150	41.7	28	76				
	180	50.0	23.5	76				
150-160B	84	23.3	27	73	2900	15	5	210
	140	38.9	24	73				
	168	46.7	21	73				
150-200	140	38.9	13.8	68	1450	15	5	253
	200	55.6	12.5	78				
	260	72.2	10.6	78				
150-200A	125	34.7	11	66	1450	11	5	234
	179	49.7	10	76				
	232.5	64.6	8.5	76				
150-200B	111.7	31.0	9.2	66	1450	7.5	5	235
	160	44.4	8	76				
	207	57.5	6.8	76				
150-250	140	38.9	21.8	73	1450	18.5	5	314
	200	55.6	20	79				
	260	72.2	17	77				
150-250A	129	35.8	18.5	72	1450	15	5	274
	184.4	51.2	17	78				
	240	66.7	14.4	76				
150-250B	117	32.5	15.2	76	1450	11	5	255
	167	46.4	14	76				
	217.5	60.4	12	76				
150-315	140	38.9	33.8	70	1450	30	5	413
	200	55.6	32	78				
	260	72.2	28	73				
150-315A	131	36.4	29.5	69	1450	22	5	345
	187	51.9	28	77				
	243	67.5	24.5	77				
150-315B	121	33.6	25	76	1450	18.5	5	335
	173	48.1	24	76				
	225	62.5	21	76				

## Flange Dimension

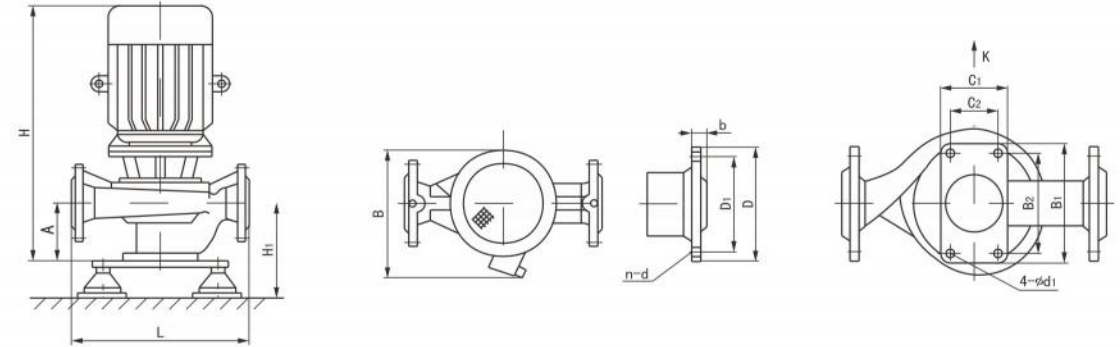

Flange dimension				
DN	D	D1	n-d	b
φ 150	φ 285	φ 240	8-φ 22	26

## Performance Table

Model	Rated flow		Rated head	Efficiency	Rotational Speed	Power	Cavitation	Weight
	m <sup>3</sup> /h	L/s	m	%	r/min	kW	m	kg
150-350	115	31.9	160	64	2900	110	5	1020
	160	44.4	150	71				
	208	57.8	139	67				
	288	79.9	128	63				
150-350A	105	29.2	152	63	2900	90	5	910
	150	41.7	142	70				
	195	54.2	131	66				
150-350B	98	27.2	110	62	2900	75	5	815
	140	38.9	101	69				
	182	50.6	90	65				
150-400	140	38.9	53	68	1450	45	5	547
	200	55.6	50	75				
	260	72.2	44	71				
150-400A	131	36.4	46.6	67	1450	37	5	511
	187	51.9	44	74				
	243	67.5	38.3	70				
150-400B	122	33.9	40	73	1450	30	5	453
	174	48.3	38	73				
	226.5	62.9	33	73				
150-400C	112	31.1	34	71	1450	22	5	388
	160	44.4	32	71				
	208	57.8	28	71				
150-500	140	38.9	83	73	1450	90	5	950
	200	55.6	80	82				
	240	66.7	75	80				
150-500A	127	35.3	73	73	1450	75	5	910
	182	50.6	70.5	82				
	218	60.6	66	80				
150-500B	116	32.2	64.5	73	1450	55	5	820
	166	46.1	62	84				
	199	55.3	58	82				
150-500C	106	29.4	59	73	1450	45	5	740
	151	41.9	56	82				
	178	49.4	52	80				
150-200(I)	140	38.9	53	65	2900	45	4.5	540
	200	55.6	50	68				
	260	72.2	44	67				
150-200(I)A	131	36.4	46.6	62	2900	37	4.5	490
	187	51.9	44	65				
	243	67.5	38.3	64				
150-200(I)B	122	33.9	40	62	2900	30	4.5	470
	174	48.3	38	65				
	226.5	62.9	33	63				
150-250(I)	120	33.3	87	65	2900	75	5	702
	200	55.6	80	76				
	240	66.7	72	74				
150-250(I)A	112	31.1	76	64	2900	55	5	561
	187	51.9	70	75				
	224	62.2	63	73				

## Flange Dimension

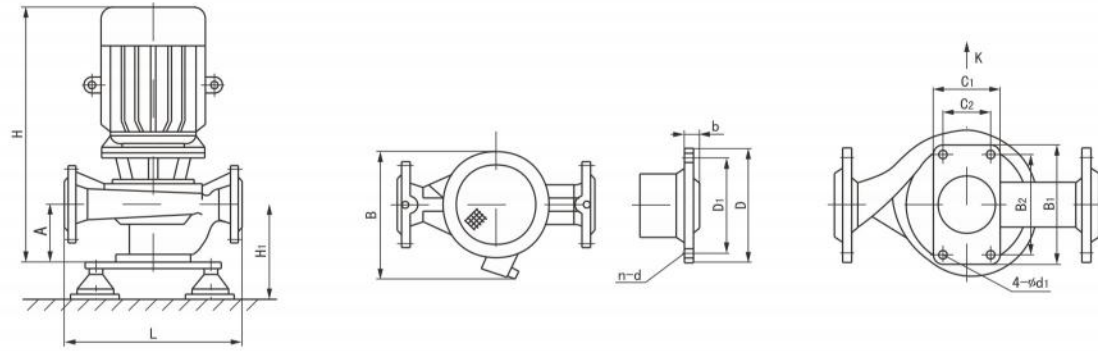

Flange dimension				
DN	D	D1	n-d	b
φ 150	φ 285	φ 240	8-φ 22	26
φ 200	φ 340	φ 295	12-φ 22	30

## Flange Dimension

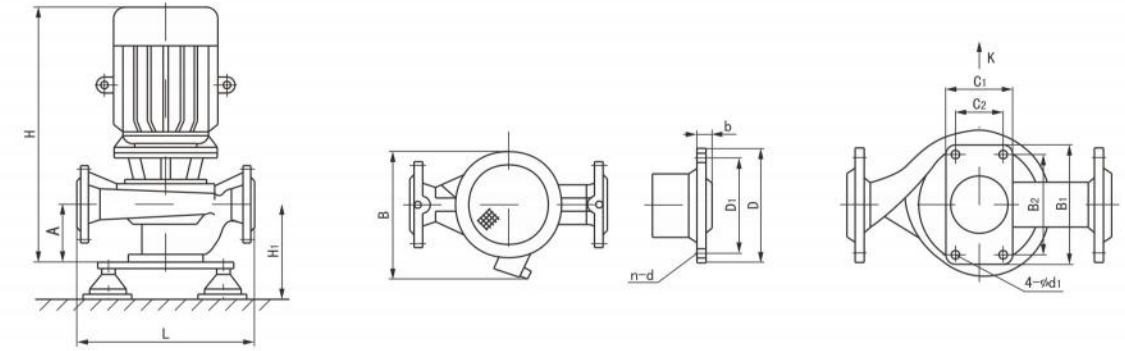

Flange dimension				
DN	D	D1	n-d	b
φ 200	φ 340	φ 295	12-φ 22	30

## Performance Table

Model	Rated flow		Rated head	Efficiency	Rotational Speed	Power	Cavitation	Weight
	m <sup>3</sup> /h	L/s	m	%	r/min	kW	m	kg
150-250(I)B	104	28.9	65	63	2900	45	5	454
	173	48.1	60	74				
	208	57.8	54	72				
150-315(I)	120	33.3	133	58	2900	110	5	1040
	200	55.6	125	73				
	240	66.7	120	75				
150-315(I)A	112	31.1	116	57	2900	90	5	800
	187	51.9	110	72				
	224	62.2	105	74				
150-315(I)B	104	28.9	100	55	2900	75	5	724
	173	48.1	95	70				
	208	57.8	91	72				
150-350(I)	126	35.0	160	66	2900	132	5	990
	180	50.0	150	72				
	234	65.0	138	68				
150-350(I)A	119	33.1	153	65	2900	110	5	740
	170	47.2	142	71				
	221	61.4	130	67				
150-350(I)B	113.4	31.5	146	64	2900	110	5	720
	162	45.0	135	70				
	210.6	58.5	123	66				
200-200	140	38.9	13.8	68	1450	15	5.5	282
	200	55.6	12.5	78				
	260	72.2	10.6	78				
200-200A	125	34.7	11	66	1450	11	5.5	273
	179	49.7	10	76				
	232.5	64.6	8.5	76				
200-250	140	38.9	21.8	73	1450	18.5	5.5	352
	200	55.6	20	79				
	260	72.2	17	77				
200-250A	129	35.8	18.5	72	1450	15	5.5	310
	184.4	51.2	17	78				
	240	66.7	14.4	76				
200-250B	117	32.5	15.2	70	1450	11	5.5	290
	167	46.4	14	70				
	217.5	60.4	12	70				
200-315	140	38.9	33.8	70	1450	30	5.5	440
	200	55.6	32	78				
	260	72.2	28	78				
200-315A	131	36.4	29.5	69	1450	22	5.5	373
	187	51.9	28	77				
	243	67.5	24.5	77				

## Performance Table

Model	Rated flow		Rated head	Efficiency	Rotational Speed	Power	Cavitation	Weight
	m <sup>3</sup> /h	L/s	m	%	r/min	kW	m	kg
200-315B	121	33.6	25	76	1450	18.5	5.5	362
	173	48.1	24	76				
	225	62.5	21	76				
200-400	140	38.9	53	68	1450	45	5.5	560
	200	55.6	50	75				
	260	72.2	44	71				
200-400A	131	36.4	46.6	67	1450	37	5.5	523
	187	51.9	44	74				
	243	67.5	38.3	70				
200-400B	122	33.9	40	73	1450	30	5.5	465
	174	48.3	38	73				
	226.5	62.9	33	73				
200-400C	112	31.1	34	71	1450	22	5.5	401
	160	44.4	32	71				
	208	57.8	28	71				
200-500	140	38.9	83	74	1450	90	5.5	1100
	200	55.6	80	82				
	240	66.7	75	79				
200-500A	127	35.3	73	74	1450	75	5.5	1100
	182	50.6	70.5	82				
	218	60.6	66	79				
200-500B	116	32.2	64.5	74	1450	55	5.5	1100
	166	46.1	62	84				
	199	55.3	58	80				
200-200(I)	280	77.8	13.4	70	1450	22	5.5	408
	400	111.1	12.5	80				
	520	144.4	10.5	79				
200-200(I)A	250	69.4	10.7	68	1450	18.5	5.5	398
	358	99.4	10	78				
	465	129.2	8.5	77				
200-250(I)	280	77.8	22.2	75	1450	30	5.5	483
	400	111.1	20	80				
	520	144.4	14	72				
200-250(I)A	250	69.4	18	73	1450	22	5.5	413
	358	99.4	16	78				
	465	129.2	11.2	70				
200-250(I)B	226	62.8	14.4	70	1450	18.5	5.5	402
	322	89.4	13	75				
	419	116.4	7.3	67				

## Flange Dimension

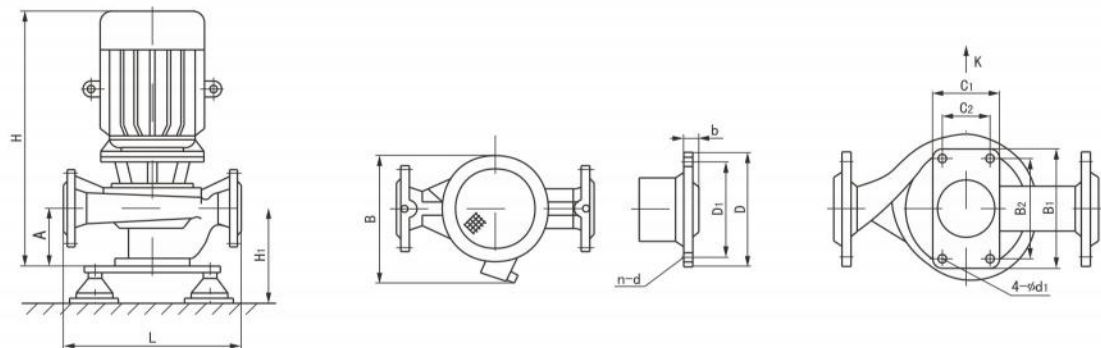

Flange dimension				
DN	D	D1	n-d	b
φ200	φ340	φ295	12-φ22	30

## Performance Table

Model	Rated flow		Rated head	Efficiency	Rotational Speed	Power	Cavitation	Weight
	m <sup>3</sup> /h	L/s	m	%	r/min	kW	m	kg
200-315(I)	280	77.8	36	73	1450	55	5.5	685
	400	111.1	32	80				
	520	144.4	26	75				
200-315(I)A	262	72.8	31.5	72	1450	45	5.5	600
	374	103.9	28	79				
	486	135.0	23	74				
200-315(I)B	242	67.2	27	78	1450	37	5.5	564
	346	96.1	24	78				
	450	125.0	19.5	78				
200-400(I)	280	77.8	54.5	75	1450	75	5.5	840
	400	111.1	50	81				
	520	144.4	39	77				
200-400(I)A	262	72.8	48	80	1450	75	5.5	840
	374	103.9	44	80				
	486	135.0	34	80				
200-400(I)B	242	67.2	41.4	78	1450	55	5.5	615
	346	96.1	38	78				
	450	125.0	29.6	78				
200-400(I)C	224	62.2	34.9	76	1450	45	5.5	615
	320	88.9	32	76				
	416	115.6	25	76				
200-500(I)	280	77.8	85	73	1450	132	5.5	1250
	400	111.1	80	77				
	520	144.4	70	76				
200-500(I)A	262	72.8	74.4	74	1450	110	5.5	1160
	374	103.9	70	79				
	486	135.0	61.2	73				
200-500(I)B	242	67.2	63.8	74	1450	90	5.5	1050
	346	96.1	60	79				
	450	125.0	52.5	73				
200-500(I)C	224	62.2	53.2	74	1450	75	5.5	906
	320	88.9	50	79				
	416	115.6	43.8	75				
200-200(II)	210	58.3	13.4	77	1480	18.5	4	380
	300	83.3	12.5					
	360	100	10.5					
200-200(II)A	196	54.4	10.3	76.1	1480	15	4	346
	280	77.8	10					
	336	93.3	8.5					

## Flange Dimension

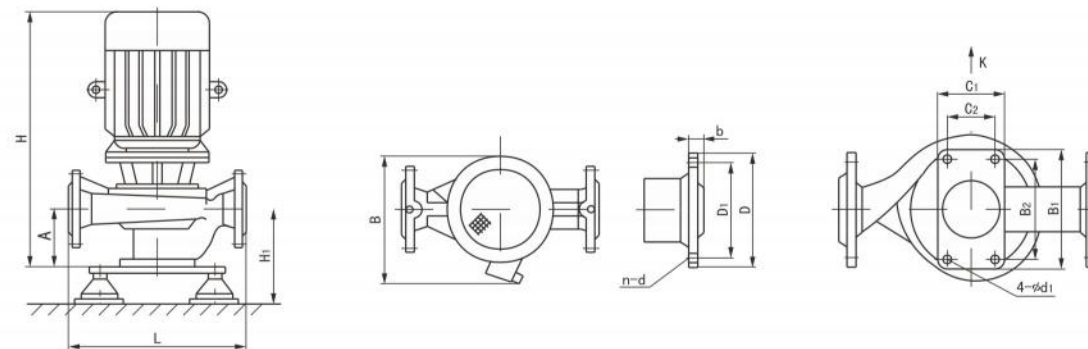

Flange dimension				
DN	D	D1	n-d	b
φ250	φ340	φ295	12-φ22	30
φ250	φ405	φ355	12-φ26	30

## Performance Table

Model	Rated flow		Rated head	Efficiency	Rotational Speed	Power	Cavitation	Weight
	m <sup>3</sup> /h	L/s	m	%	r/min	kW	m	kg
200-250(II)	210	58.3	22.2	77.9	1480	22	4	475
	300	83.3	20					
	360	100	14					
200-250(II)A	196	54.4	18	77	1480	18.5	4	380
	280	77.8	16					
	336	93.3	11.2					
200-250(II)B	182	50.6	14.6	76	1480	15	4	346
	262	72.8	13					
	312	86.7	9					
200-315(II)	210	58.3	36	77.6	1480	45	4	600
	300	83.3	32					
	360	100	26					
200-315(II)A	196	54.4	31.5	76.7	1480	37	4	560
	280	77.8	28					
	336	93.3	23					
200-315(II)B	182	50.6	27	75.7	1480	30	4	505
	262	72.8	24					
	312	86.7	19.5					
200-400(II)	210	58.3	54.5	75.3	1480	75	4	800
	300	83.3	50					
	360	100	39					
200-400(II)A	196	54.4	48	74.4	1480	55	4	708
	280	77.8	44					
	336	93.3	34					
200-400(II)B	182	50.6	41.4	73.4	1480	45	4	600
	262	72.8	38					
	312	86.7	29.6					
200-400(II)C	171	47.5	34.9	72.5	1480	37	4	600
	245	68.1	32					
	294	81.7	25					
200-500(II)	210	58.3	85	70.2	1480	110	4.5	1230
	300	83.3	80					
	360	100	73					
200-500(II)A	196	54.4	74	69.3	1480	90	4.5	906
	280	77.8	70					
	336	93.3	64					
200-500(II)B	182	50.6	64	68.3	1480	75	4.5	816
	262	72.8	60					
	312	86.7	54					
200-500(II)C	171	47.5	56	67.4	1480	55	4.5	780
	245	68.1	52					
	294	81.7	48					
250-250	350	97.2	21.8	78	1450	45	5.5	599
	550	152.7	20					
	600	166.7	18.1					
250-250A	300	83.3	18.3	76	1450	37	5.5	549
	500	138.9	17					
	600	166.7	14					

## Flange Dimension

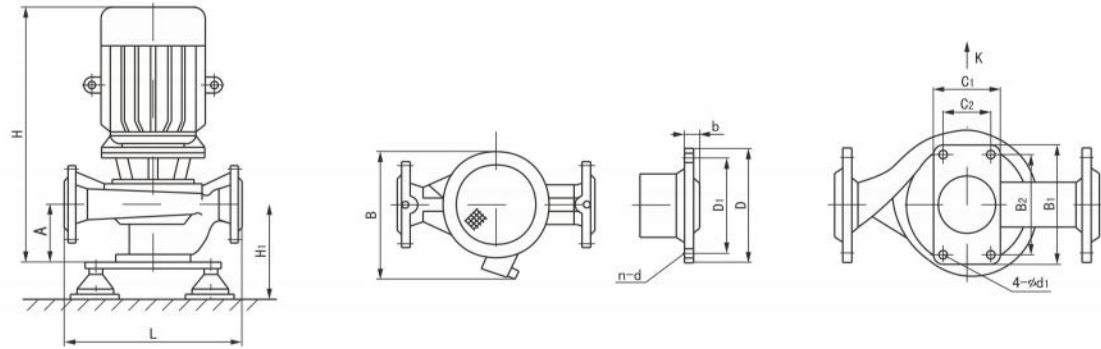

Flange dimension				
DN	D	D1	n-d	b
φ 250	φ 405	φ 355	12-φ 26	30
φ 300	φ 460	φ 410	12-φ 26	32

## Flange Dimension

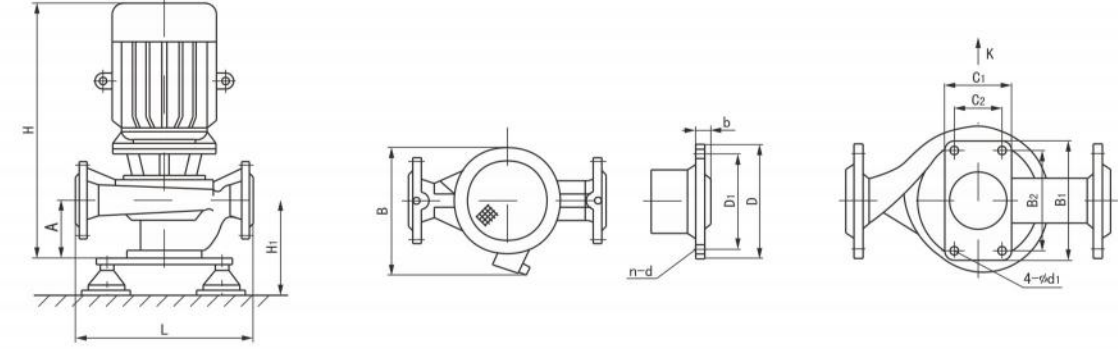

Flange dimension				
DN	D	D1	n-d	b
φ 300	φ 460	φ 410	12-φ 26	32

## Performance Table

Model	Rated flow		Rated head	Efficiency	Rotational Speed	Power	Cavitation	Weight
	m <sup>3</sup> /h	L/s	m	%	r/min	kW	m	kg
250-315	350	97.2	35	76	1450	75	5.5	1100
	550	152.8	32	80				
	600	166.7	28	78				
250-315A	350	97.2	31.5	74	1450	55	5.5	950
	500	138.9	28	78				
	600	166.7	24	77				
250-315B	350	88.5	26.5	70	1450	45	5.5	850
	450	125.0	24	74				
	540	150.0	20	72				
250-400	350	97.2	54.5	72	1450	110	5.5	1160
	550	152.8	50	72				
	600	166.7	41.5	72				
250-400A	250	69.4	47.5	72	1450	90	5.5	1050
	500	138.9	44	72				
	564	156.7	36.5	72				
250-400B	232	64.4	41	71	1450	75	5.5	960
	460	127.8	38	74				
	524	145.6	31.5	73				
250-400C	224	62.2	33	71	1450	55	5.5	880
	429	119.2	31	74				
	514	142.8	28	73				
250-500	385	106.9	87	73	1450	185	5.5	1250
	550	152.8	80	77				
	660	183.3	68	74				
250-500A	357	99.2	76.1	73	1450	160	5.5	1160
	510	141.7	70	77				
	612	170.0	59.5	74				
250-500B	329	91.4	65.2	73	1450	132	5.5	1050
	470	130.6	60	77				
	564	156.7	51	74				
250-500C	301	83.6	54.3	74	1450	110	5.5	940
	430	119.4	50	80				
	516	143.3	42.5	77				
300-235	540	150.0	20.5	76	1450	55	5.5	1075
	720	200.0	18	82				
	900	250.0	15	78				
300-235A	450	125.0	17.2	76	1450	45	5.5	970
	600	166.7	15	82				
	720	200.0	12.5	78				

## Performance Table

Model	Rated flow		Rated head	Efficiency	Rotational Speed	Power	Cavitation	Weight
	m <sup>3</sup> /h	L/s	m	%	r/min	kW	m	kg
300-235B	420	116.7	14.3	76	1450	37	5.5	925
	540	150	12.8	82				
	650	181	10.5	78				
300-250	540	150.0	22.5	76	1450	55	6	1085
	720	200.0	20	82				
	900	250.0	17	78				
300-250A	450	136.0	19.5	76	1450	45	6	980
	600	166.7	17	82				
	720	200.0	14	78				
300-315	540	150.0	35	76	1450	90	6	1230
	720	200.0	32	82				
	900	250.0	28	78				
300-315A	460	127.8	31.5	76	1450	75	6	1095
	662	183.9	28	82				
	791	219.7	24	78				
300-315B	423	117.5	26.5	76	1450	55	6	970
	609	169.2	24	81				
	728	202.2	20	78				
300-400	500	128.9	54	84	1450	132	5.5	1500
	720	200.0	50	85				
	900	250.0	42	82				
300-400A	460	127.8	47	84	1450	110	5.5	1255
	662	183.9	44	85				
	791	219.7	37	82				
300-400B	423	117.5	41	84	1450	90	5.5	1220
	609	169.2	38	85				
	728	202.2	32	82				
300-400C	373	103.6	33	84	1450	75	5.5	1100
	536	148.9	31	87				
	641	178.1	28	83				
300-460	480	133.3	71	75	1450	185	5.5	1350
	720	200.0	65	81				
	900	250.0	58	82				
300-460A	444	123.3	60	74	1450	160	5.5	1230
	666	185.0	55	80				
	830	231.4	49	81				
300-460B	409	113.6	49	73	1450	110	5.5	1125
	614	170.6	45	79				
	767	213.1	35	80				

## Flange Dimension

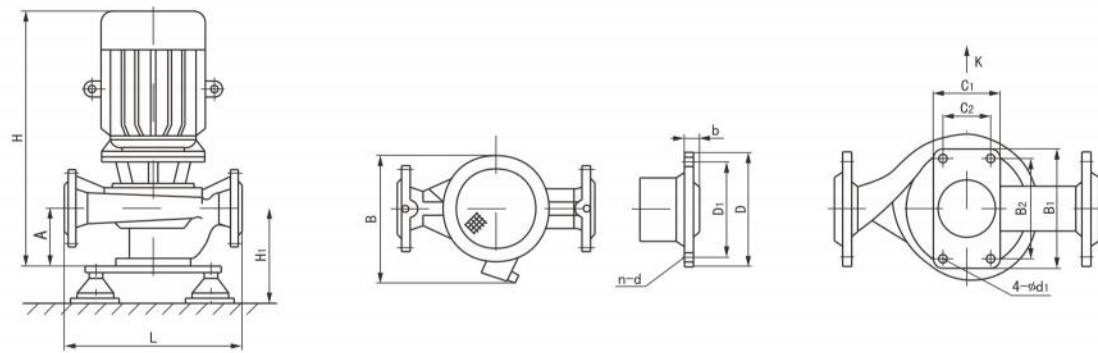

Flange dimension				
DN	D	D1	n-d	b
φ300	φ460	φ410	12-φ26	32
φ350	φ520	φ470	16-φ26	34

## Performance Table

Model	Rated flow		Rated head	Efficiency	Rotational Speed	Power	Cavitation	Weight
	m <sup>3</sup> /h	L/s	m	%	r/min	kW	m	kg
300-500	540	150.0	85	78	1450	250	5.5	1685
	720	200.0	80	80				
	900	250.0	70	78				
300-500A	506	140.6	74.4	77	1450	200	5.5	1565
	675	187.5	70	79				
	720	200.0	61.2	77				
300-500B	468	130.0	63.8	76	1450	160	5.5	1472
	625	173.6	60	78				
	667	185.3	52.5	76				
300-500C	425	118.1	63.2	75	1450	110	5.5	1345
	570	158.3	50	77				
	605	168.1	43.8	75				
350-250	720	200.0	24	82	1450	90	5.5	1230
	1200	333.3	20	82				
	1440	400.0	17	82				
350-250A	650	180.6	19.5	81	1450	75	5.5	1100
	1080	300.0	16	81				
	1300	361.1	13.5	81				
350-315	720	200.0	36	81	1450	160	5.5	1650
	1200	333.3	32	81				
	1440	400.0	28	81				
350-315A	670	186.1	31	80	1450	132	5.5	1510
	1120	311.1	28	80				
	1340	372.2	24	80				
350-315B	625	173.6	27	78	1450	110	5.5	1370
	1040	288.9	24	78				
	1250	347.2	20	78				
350-400	720	200.0	55	80	1450	250	5.5	1950
	1200	333.3	50	80				
	1440	400.0	45	80				
350-400A	670	186.1	47.5	79	1450	220	5.5	1810
	1120	311.1	44	79				
	1340	372.2	39	79				
350-400B	625	173.6	41.5	78	1450	200	5.5	1690
	1040	288.9	38	78				
	1250	347.2	34	78				
350-400C	670	186.1	33	82	1450	160	5.5	1530
	905	251.4	31	86				
	1073	298.1	28	84				

## Accessories And Installation Dimension

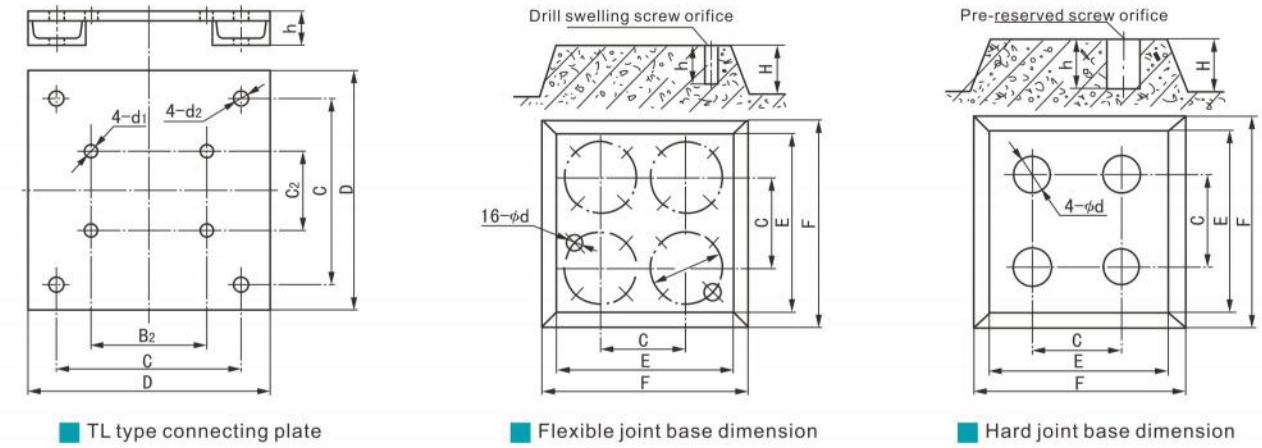

Model	TL coupling plate size			Flexible joint base dimension					Rigid joint base dimension										
	B2 × C2	C × C	D × D	h	φd1	φd2	H	E	F	C	φD	φD	h	H	E	F	C	φD	h
TL-1	45 × 70	240 × 240	300 × 300	50	φ12	φ10	200	450	500	240	φ14.5	φ14.5	60	200	450	500	240	60	200
TL-2	50 × 80	240 × 240	300 × 300	50	φ14	φ12	200	450	500	240	φ14.5	φ14.5	60	200	450	500	240	60	200
TL-3	60 × 100	240 × 240	300 × 300	50	φ14	φ12	200	450	500	240	φ14.5	φ14.5	60	200	450	500	240	60	200
TL-4	70 × 120	240 × 240	300 × 300	50	φ18	φ16	200	450	500	240	φ14.5	φ14.5	60	200	450	500	240	60	200
TL-5	80 × 130	240 × 240	300 × 300	50	φ18	φ16	200	450	500	240	φ14.5	φ14.5	60	200	450	500	240	60	200
TL-6	100 × 160	240 × 240	300 × 300	50	φ18	φ16	200	450	500	240	φ14.5	φ14.5	60	200	450	500	240	60	200
TL-7	120 × 180	340 × 340	400 × 400	50	φ18	φ16	250	650	700	340	φ14.5	φ14.5	60	250	650	700	340	80	250
TL-8	150 × 240	340 × 340	400 × 400	50	φ22	φ16	250	650	700	340	φ14.5	φ14.5	60	250	650	700	340	80	250
TL-9	180 × 270	440 × 440	500 × 500	50	φ22	φ18	300	750	800	440	φ14.5	φ14.5	60	300	750	800	440	80	250
TL-10	200 × 250	440 × 440	500 × 500	50	φ22	φ18	300	750	800	440	φ14.5	φ14.5	60	300	750	800	440	80	250
TL-11	210 × 260	440 × 440	500 × 500	50	φ22	φ18	300	750	800	440	φ14.5	φ14.5	60	300	750	800	440	80	250
TL-12	230 × 280	540 × 540	600 × 600	50	φ22	φ18	300	800	850	540	φ14.5	φ14.5	60	300	800	850	540	80	250
TL-13	250 × 320	540 × 540	600 × 600	50	φ22	φ18	300	800	850	540	φ14.5	φ14.5	60	300	800	850	540	80	250
TL-14	300 × 350	720 × 720	800 × 800	50	φ22	φ22	350	1000	1100	740	φ14.5	φ14.5	60	350	1000	1100	740	80	250
TL-15	350 × 450	720 × 720	800 × 800	50	φ26	φ22	350	1000	1100	740	φ14.5	φ14.5	60	350	1000	1100	740	80	250
TL-16	400 × 450	720 × 720	800 × 800	50	φ26	φ22	350	1000	1100	740	φ14.5	φ14.5	60	350	1000	1100	740	80	250
TL-17	400 × 500	720 × 720	800 × 800	50	φ26	φ22	350	1000	1100	740	φ14.5	φ14.5	60	350	1000	1100	740	80	250
TL-18	500 × 600	720 × 720	800 × 800	50	φ26	φ22	350	1000	1100	740	φ14.5	φ14.5	60	350	1000	1100	740	80	250

Model	M	D	D1	H	h	d	n
JD1-1	10	100	80	45	8	8	4
JD1-2	10	100	80	45	8	8	4
JD2-1	12	150	130	65	10	8	4
JD2-2	12	150	130	65	10	8	4
JD3-1	16	200	170	90	12	12	4
JD3-2	16	200	170	90	12	12	4
JD4-1	20	290	260	135	17	12	4
JD4-2	20	290	260	135	17	12	4

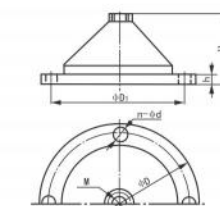

JD type vibration isolator mounting dimensions

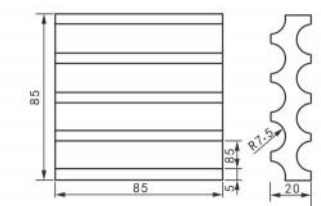

SD type vibration cushion Dimensions